

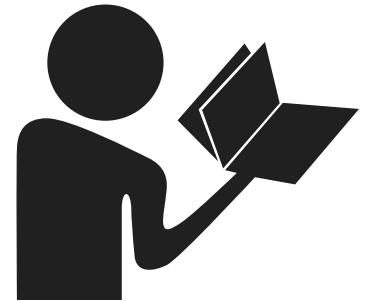

Operator Manual (EN)

Models:

17" & 20" Disk
24" Grout
20" & 24" Orbital

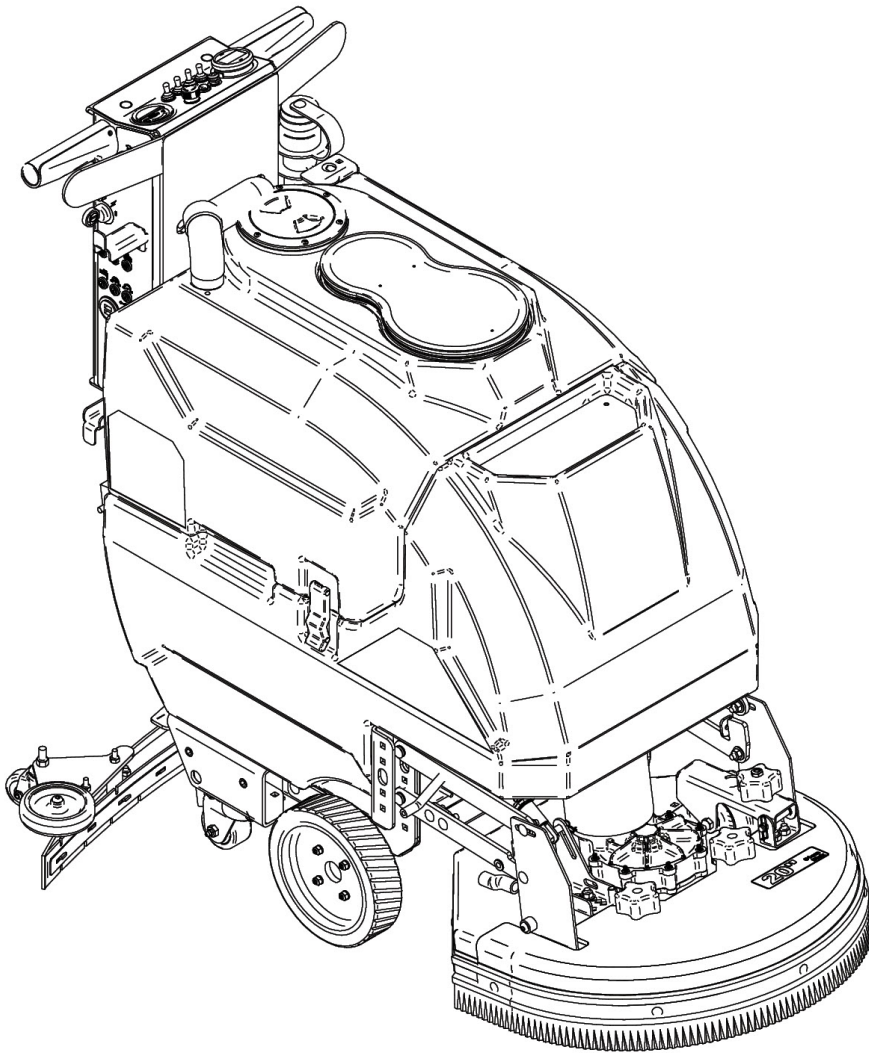

Read the Operators Manual
before using the machine.



Read the Safety Messages
before servicing machine.

INTRODUCTION

This manual is furnished with each new machine. This manual will allow the Operator to get the best performance out of your RPS manufactured Scrubber-Drier, Sweeper, Burnisher, or Orbital Scrubber. Read this manual thoroughly before operating or servicing the machine.

This machine will provide excellent performance, but the best results will be obtained at the most minimum costs if:

- The machine is regularly maintained - per the Authorized Local Distributor.
- The machine is operated with reasonable care and caution.
- The machine is maintained with manufacturer supplied parts.

Locate Serial Number

The serial number of your machine is located on the lower half of the control panel of the machine.

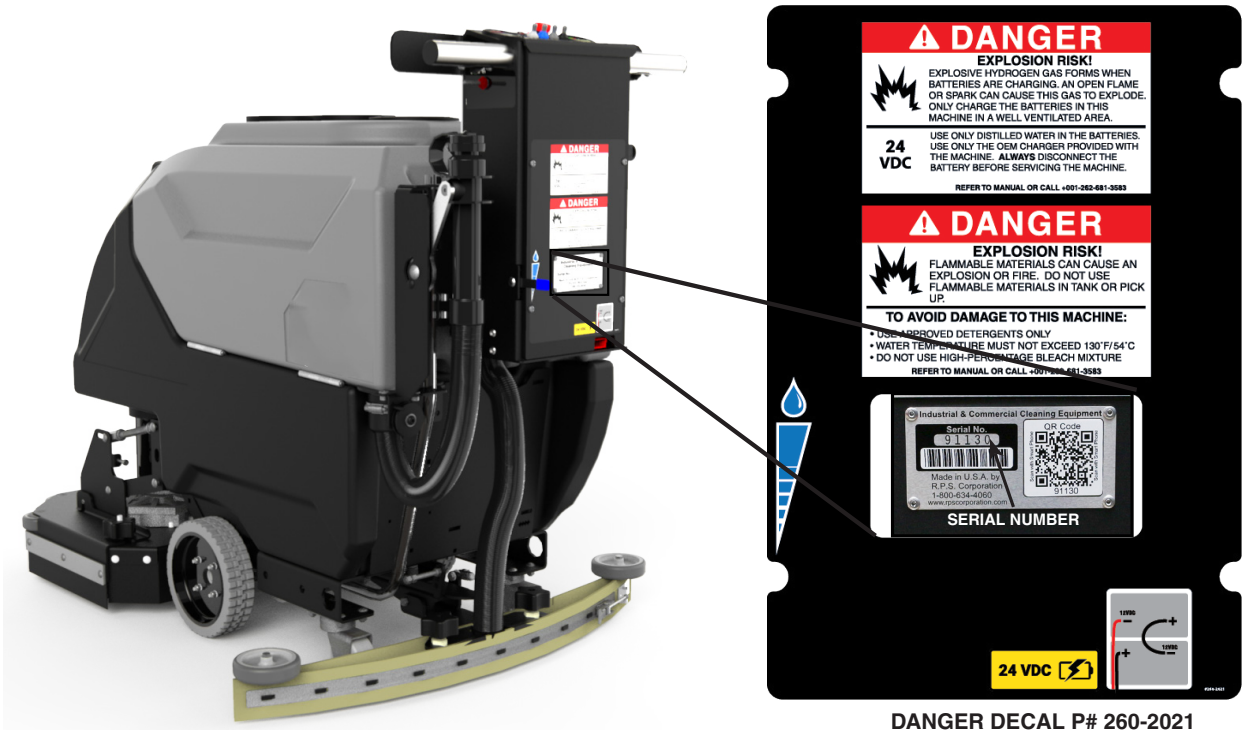

AS OUR POLICY IS ONE OF CONSTANT IMPROVEMENT - ALL INFORMATION AND SPECIFICATIONS ARE SUBJECT TO CHANGE WITHOUT NOTICE.

Intended use

The Timberline S-Series walk-behind scrubber is intended for commercial applications with hard floor surfaces such as concrete, VCT, tile and grout, stone, ect. This machine is not designed to clean carpets or sand wooden surfaces. Use only OEM pads/brushes and commercially available floor cleaning detergents. Do not use this machine other than described in this Operator Manual.

Machine Data

Fill out while installing machine for future reference.

Model No. - _____
Serial No. - _____
Installation Date - _____

Uncrating Machine

Inspect machine for damage before unloading, if any damage has occurred report it to the carrier. Contact distributor or RPS Corp. for missing components.

Remove protective shipping frame then locate and unscrew the metal bracket connecting the machine to the pallet. Before removal the scrub head should be in the raised position. Using the supplied ramp carefully back the machine off the pallet.



INTRODUCTION

Locate Serial Number 2
Intended use 2
Machine Data 2
Uncrating Machine 2

SAFETY

Important Safety Messages 4
Safety Labels 5

OPERATION

Machine Overview 6
Central Command Overview 7
Squeegee Installation 8
Squeegee Adjustment 9
Battery Setup 10
Battery Charger Use 11
Forward Drive 12
Reverse Drive 13
Fill Solution Tank 14
Scrubbing 15
Drying 16
Drain Recovery Tank 17
Flushing Recovery Tank 18

OPTIONS

Vac Wand 19
Onboard Charger 20
Brush Pressure +/- 21
Vac Clog Light 22
Charge Batteries 23

WEEKLY MAINTENANCE (<25 HRS)

Clean White Filter/Screen 24
Remove Disk Brushes 25
Rotate Grout Brush 26
Replace Orbital Pads 27
Clean Solution Filter 28
Squeegee Blade Replacement 29
Drain Solution Tank 30

MONTHLY MAINTENANCE (<100 HRS)

Deck Shroud Curtain Replacement 31
Grout Side Wiper Replacement 32
Deck Leveling 33

OTHER

Common Wear Parts 34
Common Wear Parts 35
Squeegee Blade Kits 36
PM Sheet 37
Battery Chargers 39
Status Light Error Codes 40
Codes after Serial # 125571 41
Schematic after Serial # 125571 42
Schematics 43
Schematics Adjusted Down Pressure 44
Decals 45

SAFETY

Important Safety Messages

You will see four kinds of safety reminders in this manual:

<p>⚠ DANGER</p> <p>DANGER indicates a hazardous situation which, if not avoided, will result in death or serious injury.</p>	<p>⚠ WARNING</p> <p>WARNING indicates a potentially hazardous situation which, if not avoided, could result in death or serious injury.</p>
<p>⚠ CAUTION</p> <p>CAUTION indicates a potentially hazardous situation which, if not avoided, could result in minor or moderate injury or damage to this machine or nearby objects. CAUTION also can be used to alert against unsafe practices.</p>	<p>NOTICE</p> <p>NOTICE indicates information considered important, but not hazard-related. This safety message may be related to property damage or warranty warnings.</p>

Your safety, and that of others, is very important. Operating this machine safely is an important responsibility.

DO NOT OPERATE THIS MACHINE:

- Unless you are trained and authorized to do so by your RPS Authorized Local Distributor
- Unless you have read and understood this Operator's Manual
- On surfaces with greater than a 3° slope.
- Within 25' (8m) of Loading Docks

WHEN OPERATING THIS MACHINE:

- Remove loose objects from the floor that could be projected from the rotating Brushes
- Keep your hands and feet away from the rotating Brushes
- Do not operate this machine where flammable liquids, vapors, or dust are present
- Use caution when maneuvering

BEFORE LEAVING THE MACHINE:

- Drain "clean" Solution & "dirty" Recovery solution into APPROVED drains
- Park the machine on a level surface
- Turn the machine off & remove key

BEFORE SERVICING THE MACHINE:

- Disconnect the Batteries

<p>⚠ DANGER</p> <p>Explosive hydrogen gas forms when Batteries are charging. An open flame or spark can cause this gas to explode. Serious personal injury or property damage could occur. Only charge the Batteries in this machine in a well ventilated area.</p>	<p>⚠ DANGER</p> <p>Flammable materials can cause an explosion or fire. Do not use flammable materials in Tank or pick up.</p>
--	--

! WARNING

The Batteries in this machine produce hazardous voltage which can cause electrical shock, burns and/or electrocution. Always disconnect Batteries before servicing this machine.

! WARNING

When climbing or descending ramps, always drive machine forward. To avoid overturning the machine, Do not back down ramps. Do not drive across inclines. Do not turn while ascending or descending ramps. Overturning the machine can cause serious injury or death.

! WARNING

Do not use water that exceeds 135°F / 57°C. If water is above said temperature, this will void the Tank Warranty.

! WARNING

Do not park this machine on ramps or slopes. Always park this machine on a level, hard surface. Do not operate this machine outdoors or on uneven surfaces.

! WARNING

The Batteries in this machine contain sulfuric acid, which causes burns to skin. If battery acid contacts clothing or skin, rinse the effected area with cold water immediately. If battery acid gets on your face or in your eyes, flush the area immediately with cold water and seek medical attention.

! WARNING

To avoid electrical shock, do not operate this machine over electrical floor outlets.

! CAUTION

To avoid damage to this machine, use only cleaning solutions and replacement parts recommended by the manufacturer.

! CAUTION

Do not operate this machine if any parts have been damaged or removed.

! WARNING

Dress safely. Do not wear rings or metal wrist watches when servicing this machine, as they can cause an electrical short circuit which can cause serious burns.

! WARNING

Do not remove, paint over or destroy warning decals. If warning decals become damaged, call 1-262-681-3583 for free replacements.

! WARNING

Dress safely. Do not wear a neck tie, scarf, or any loose or dangling clothing while operating this machine. Loose or dangling clothing or neck-wear can tangle in rotating parts, causing serious injury or death.

! WARNING

Always turn off this machine before leaving it unattended. Do not allow untrained persons to operate this machine.

! WARNING

NO RIDERS. Do not carry passengers on this machine. Do not use this machine as a stepladder or work platform.

! WARNING

Understand the dynamic braking system before you operate the machine on ramps. Machine may coast.

! WARNING

Before you service a Battery, always wear face protection, protective gloves and protective clothing. Battery acid or battery explosion can cause serious injuries.

! CAUTION

Always use the automatic battery charger provided by the manufacturer of this machine to charge the Batteries of this machine. It is designed to charge the Batteries at the appropriate rate. If you must use a different charger, disconnect the Batteries before charging to avoid damage to the electronic speed controller.

! CAUTION

To avoid damage to the electronic control components of this machine, Do not store this machine outdoors. Do not pressure wash this machine.

OPERATION

Machine Overview

1. Recovery Tank
2. Vac Motor
3. 3x 12VDC Batteries
4. Solution Tank
5. Squeegee
6. Rear Caster Wheel
7. Tire
8. Scrub Deck
9. Recovery Tank Clean Out
10. Foam Float Ball & White Filter
11. Solution Fill
12. Tank Latch
13. Charging Port
14. Recovery Drain Hose
15. Solution Sight Tube & Drain Hose
16. Squeegee Lever

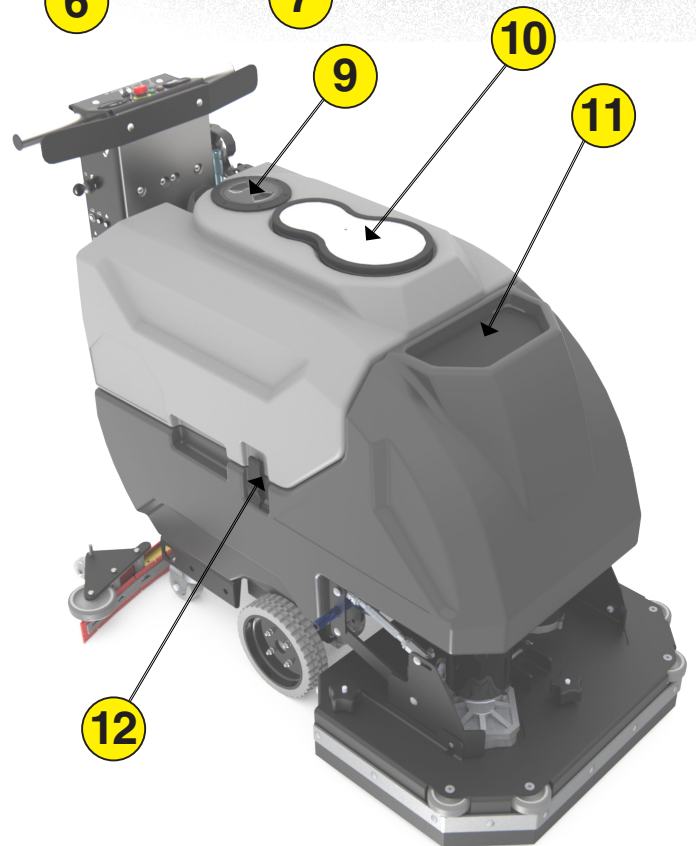
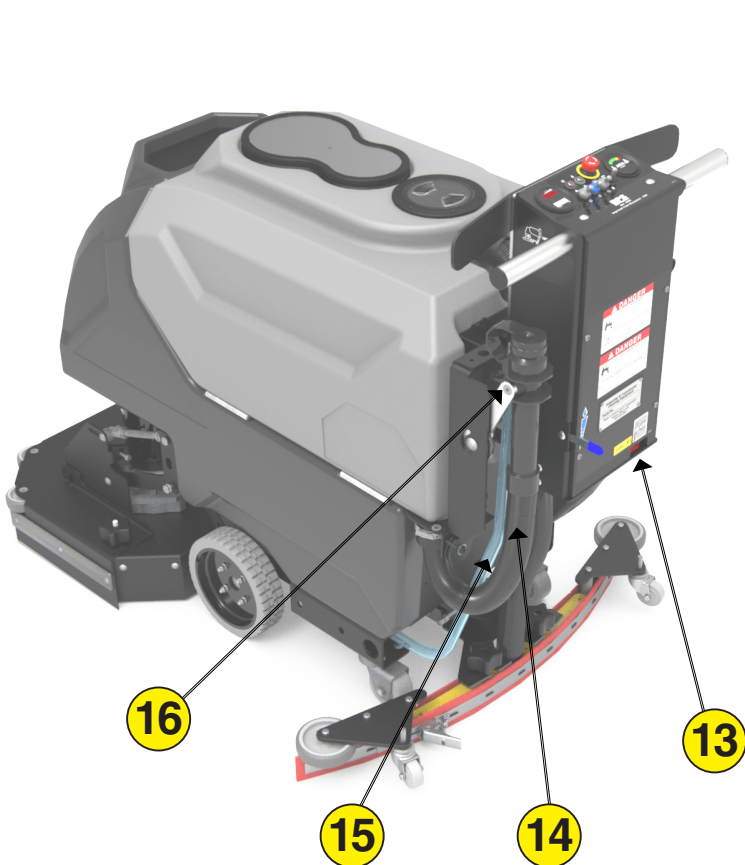
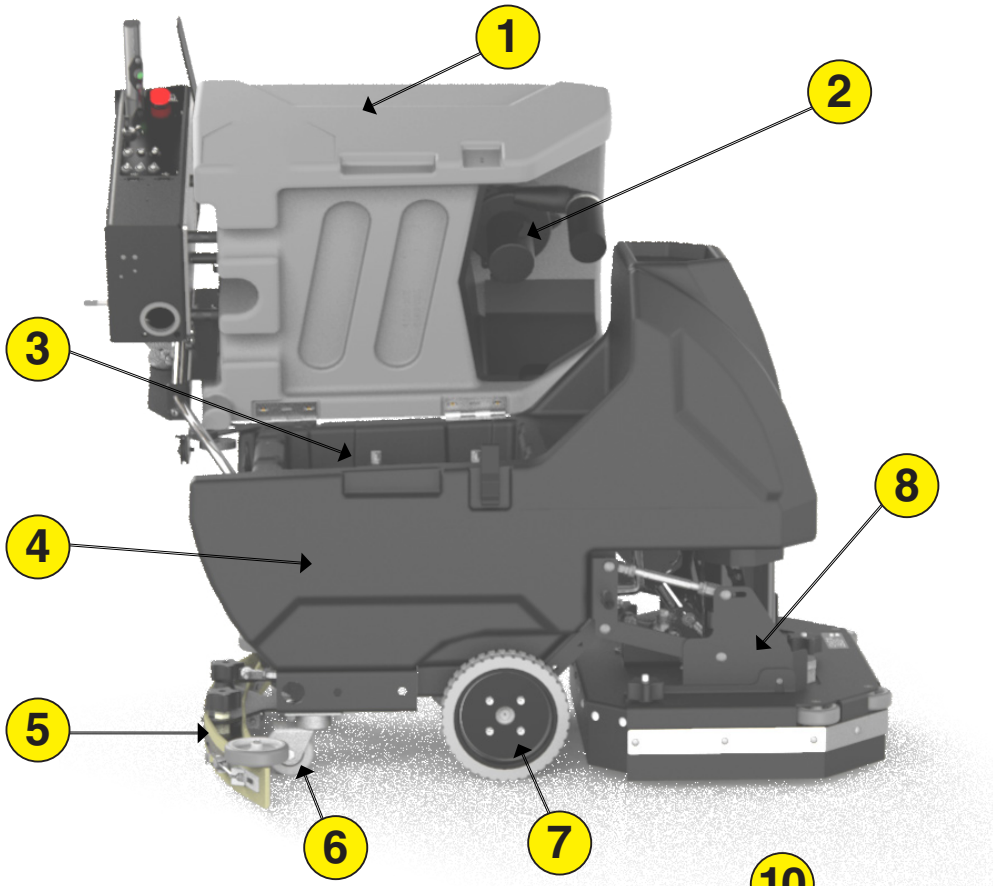

Central Command Overview

- | | |
|----------------------------------|--|
| 1. Drive Switch | 12. Battery Gauge/Hour Meter |
| 2. Key Switch | 13. Vac Clog Indicator Light (Optional) |
| 3. Right Brush Circuit Breaker | 14. Solution Indicator Light |
| 4. Left Brush Circuit Breaker | 15. E-Stop |
| 5. Positive BUSS Circuit Breaker | 16. Brush Pressure Gauge |
| 6. Pump Circuit Breaker | 17. Vac Switch I/O |
| 7. USB Port (Optional) | 18. Solution Switch I/O |
| 8. USB Port (Optional) | 19. Deck Switch Up (I) / Down (O) |
| 9. Negative BUSS Circuit Breaker | 20. Down Pressure Toggle Switch (Optional) |
| 10. Vac Circuit Breaker | 21. Drive Switch |
| 11. Speed Control Knob | 22. Reverse Switch |

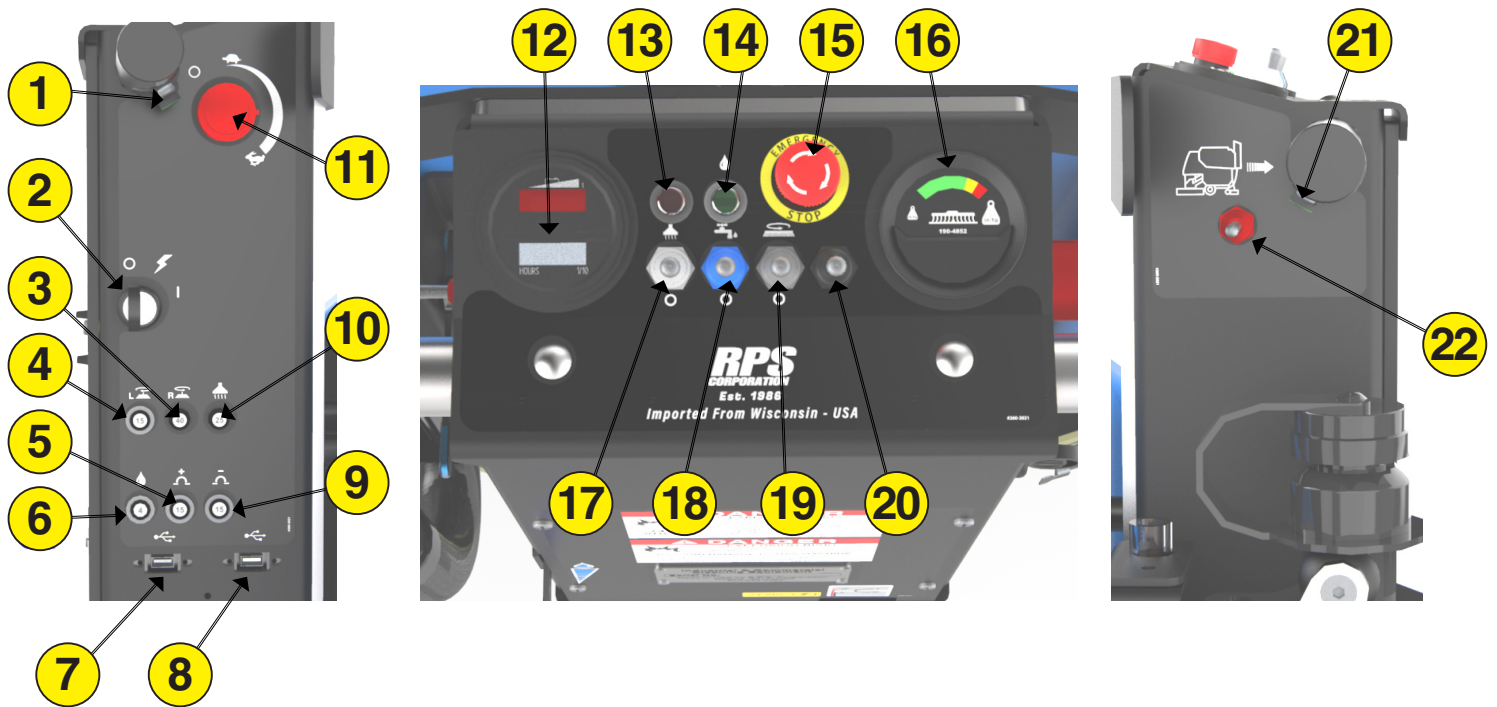

OPERATION

Squeegee Installation

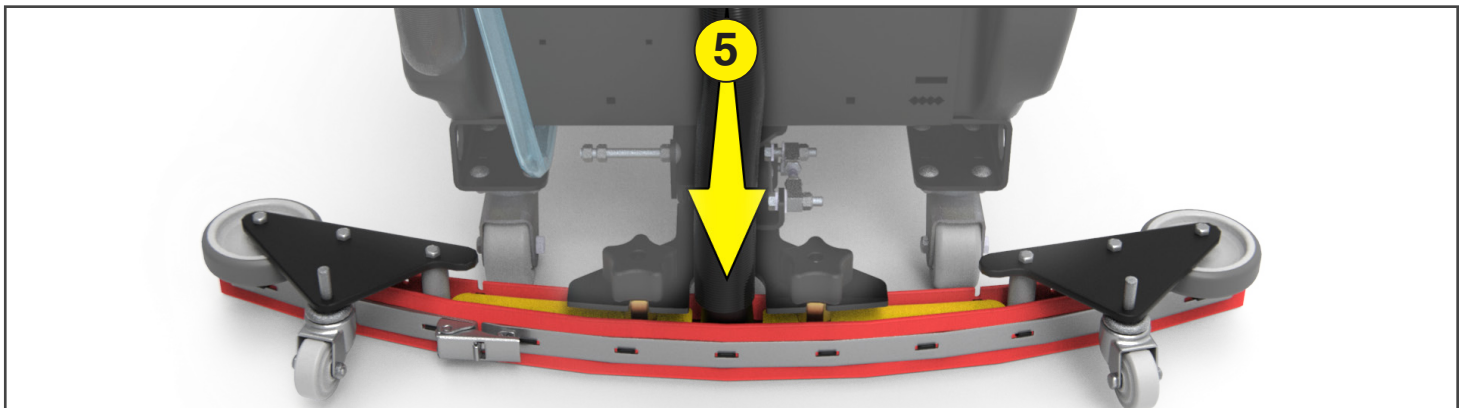
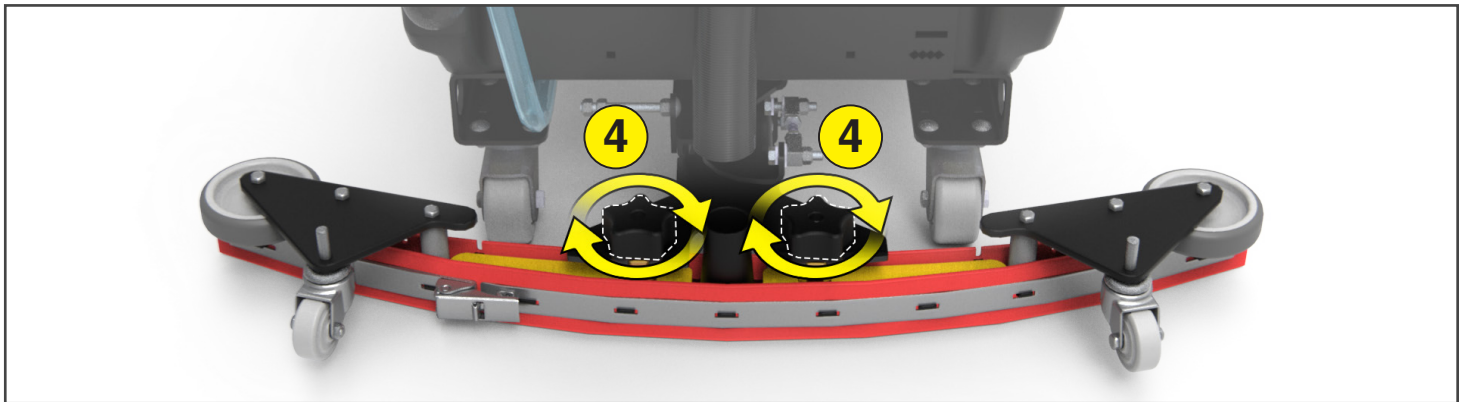
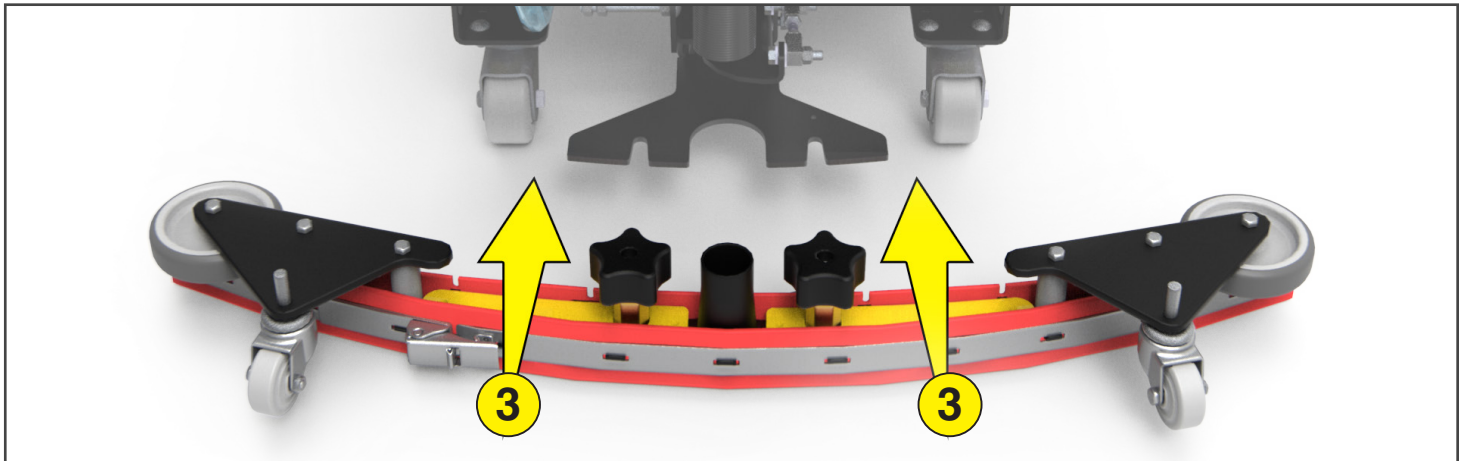
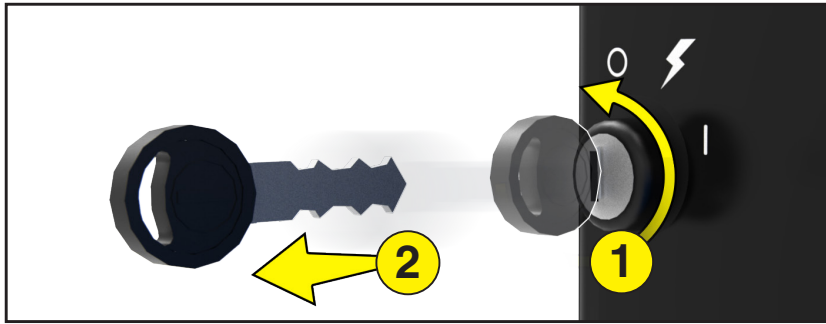
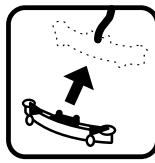

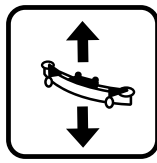

OPERATION

Squeegee Adjustment

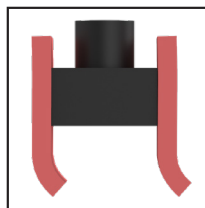
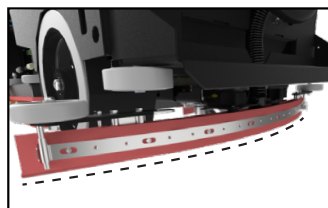
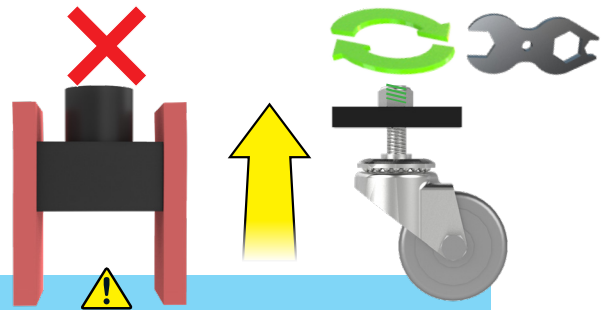
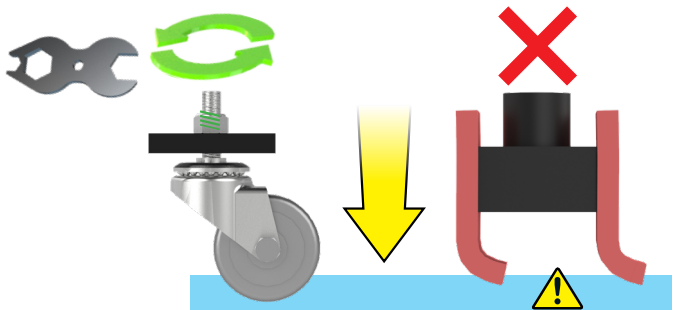
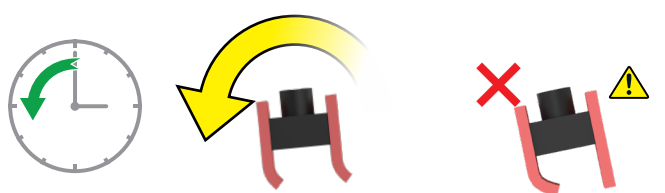
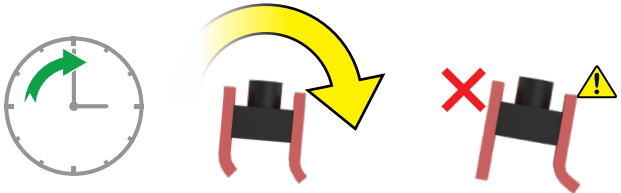
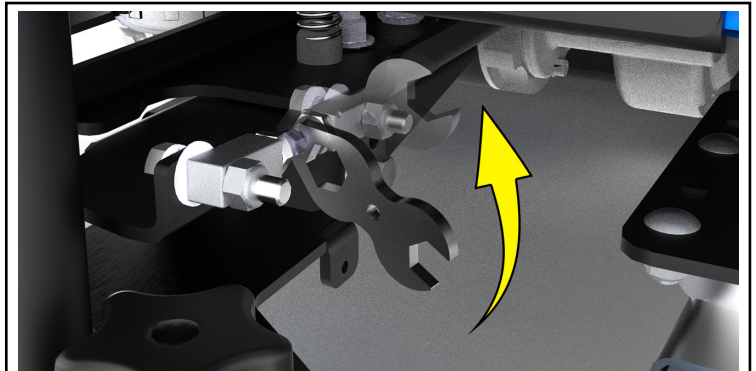
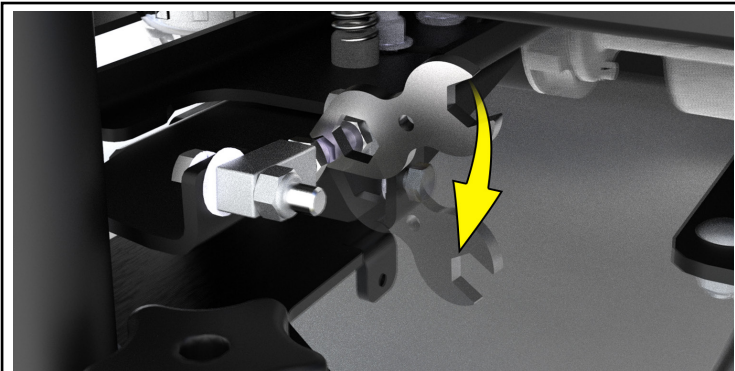
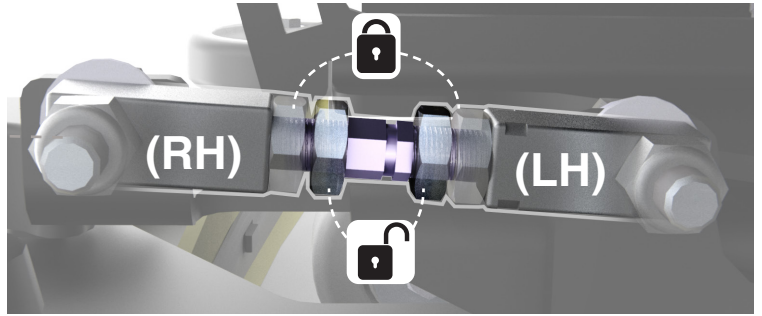
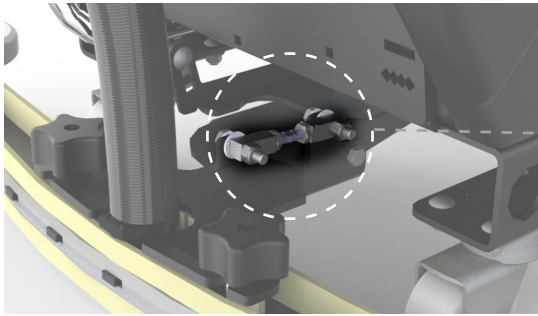
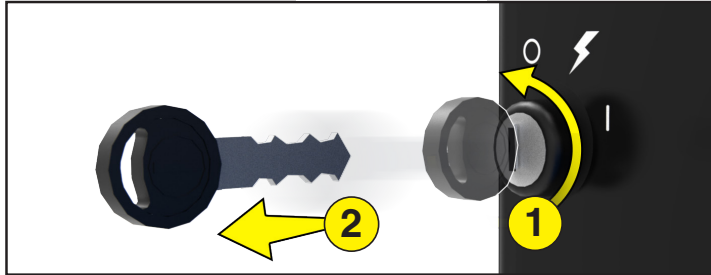

OPERATION

Battery Setup

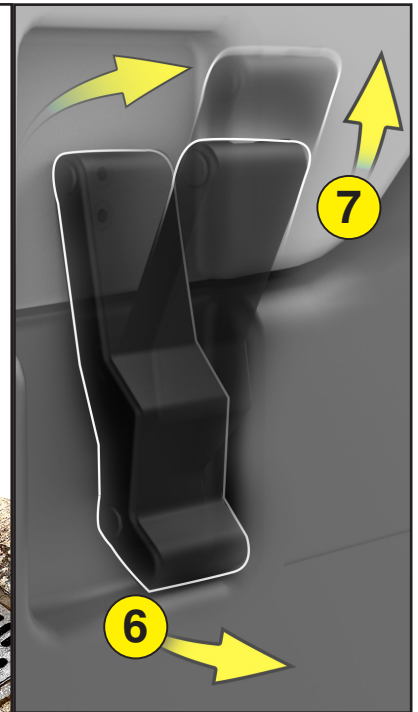
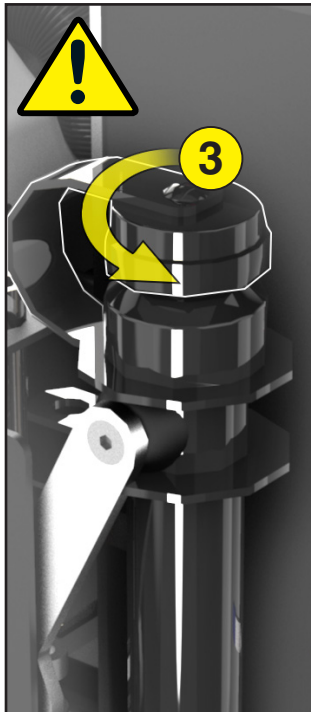
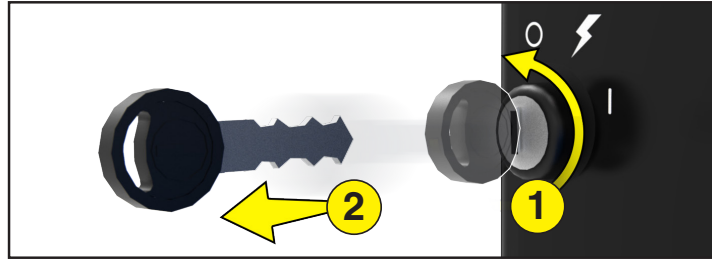
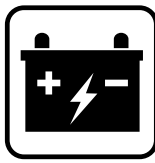

Machine On Level Ground

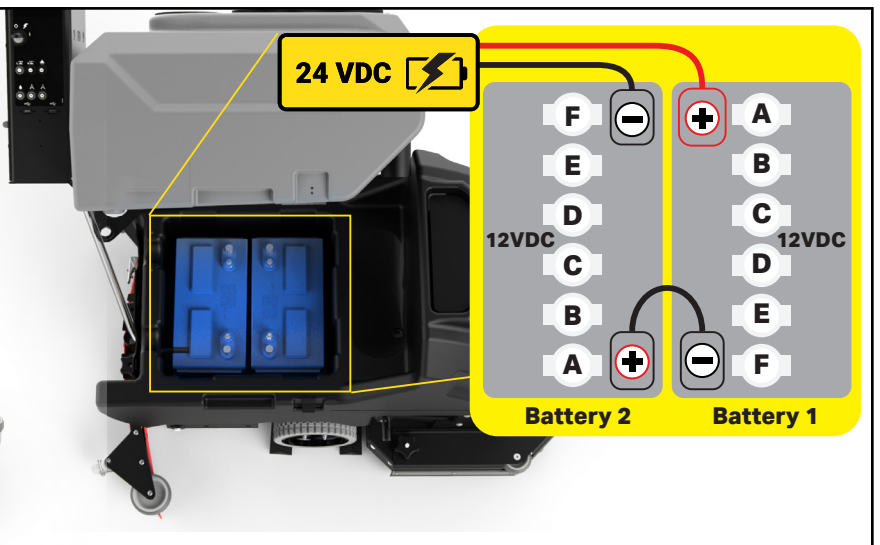
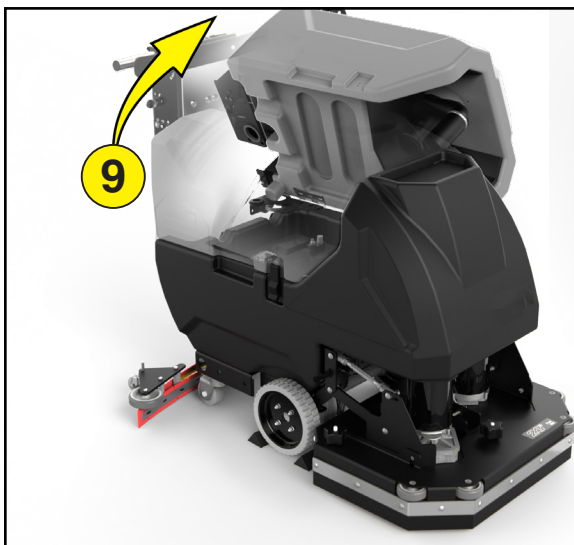

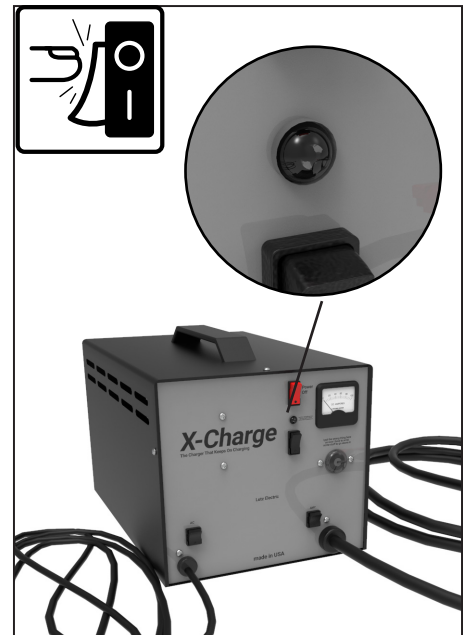
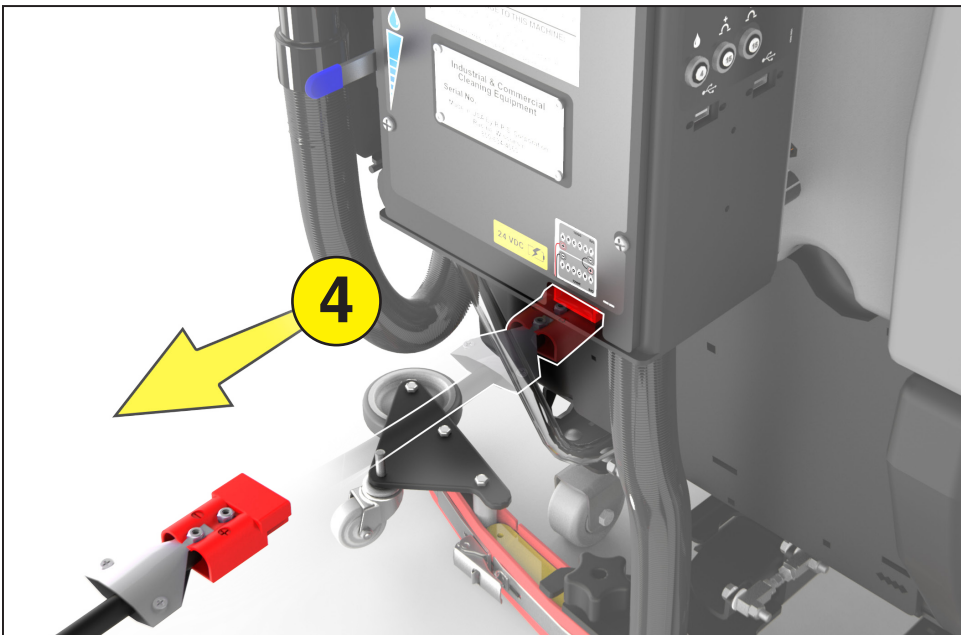
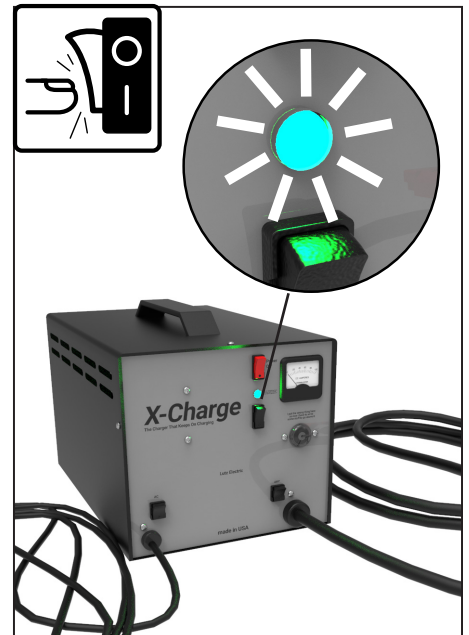
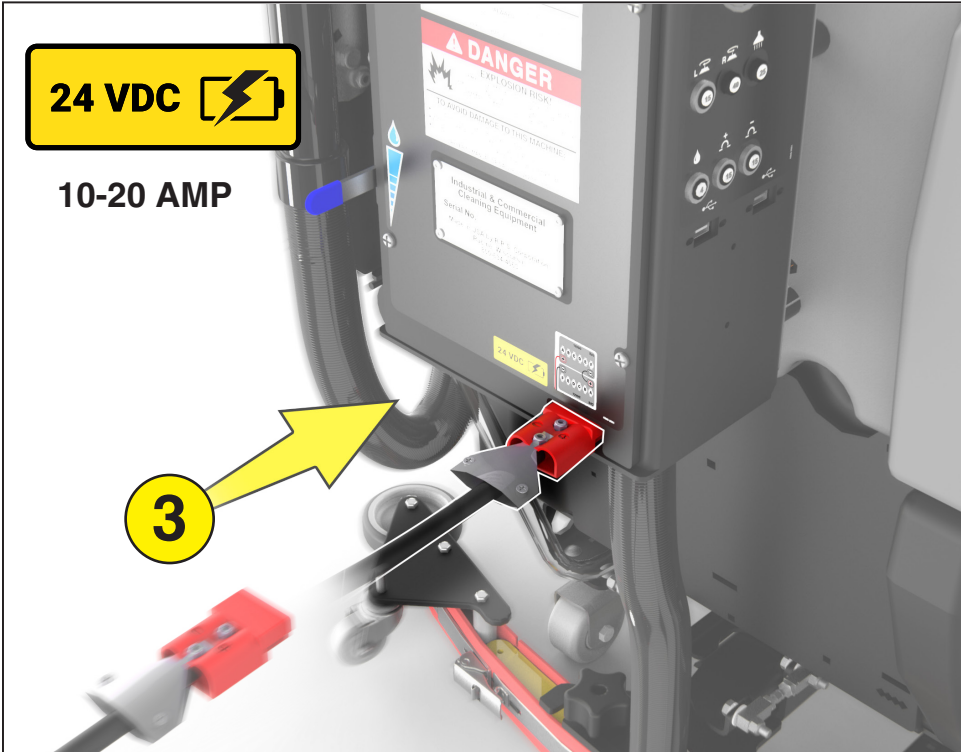
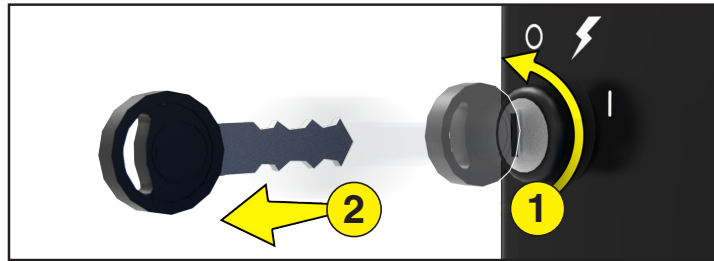
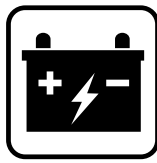

OPERATION

Forward Drive

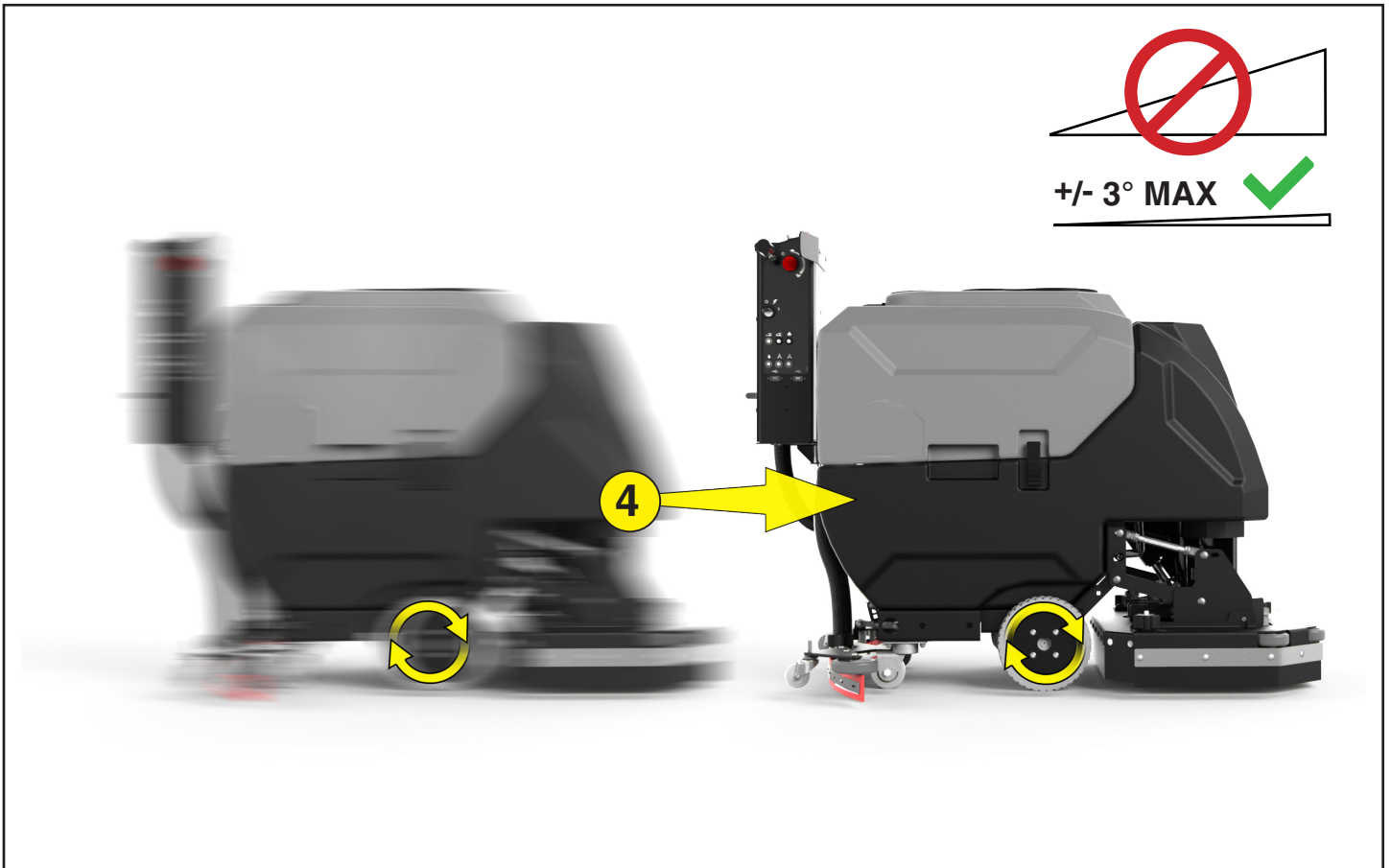
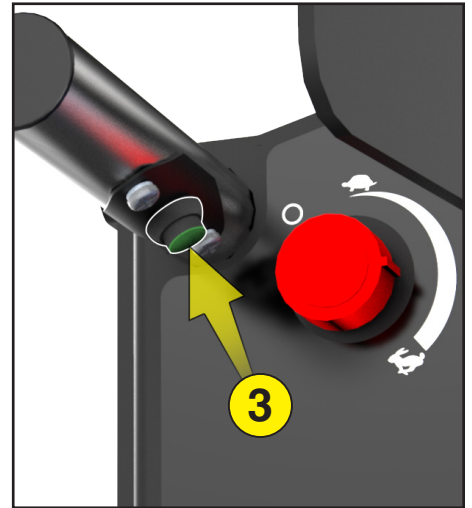
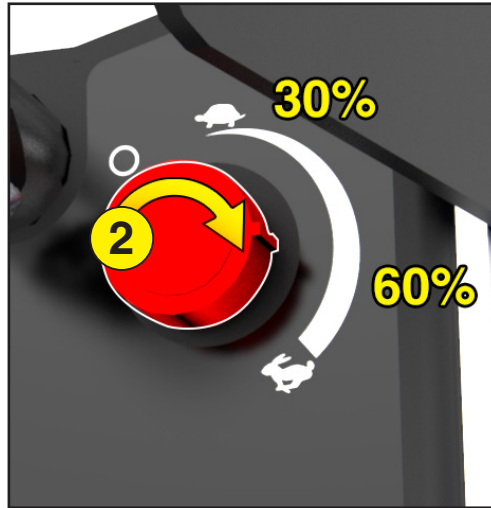



OPERATION

Reverse Drive

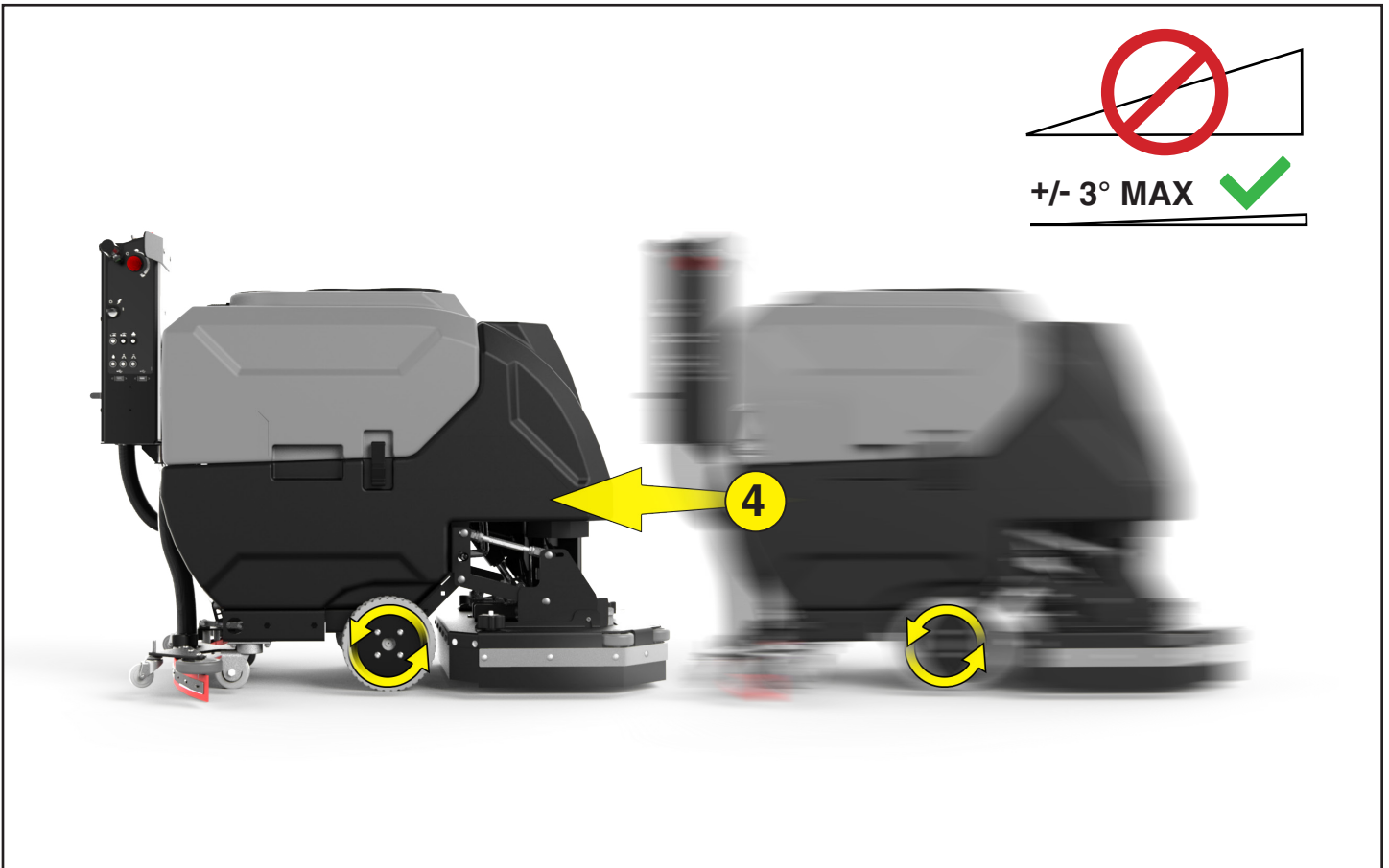
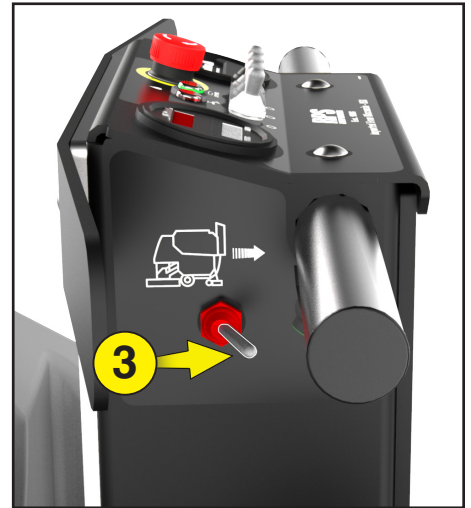
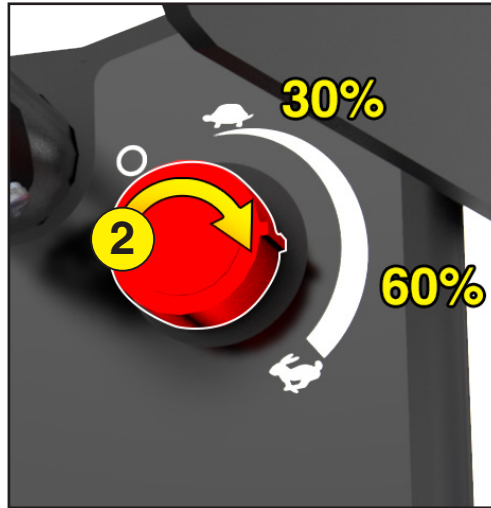

OPERATION

Fill Solution Tank

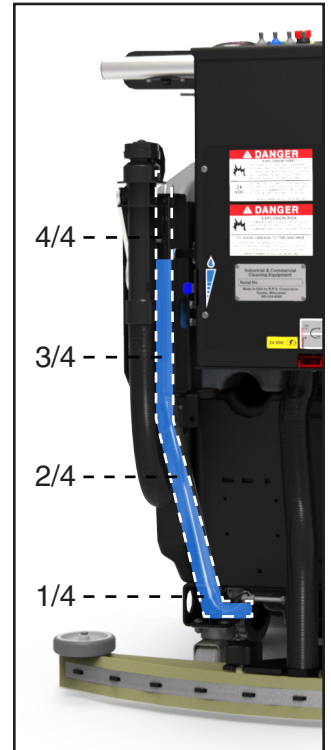
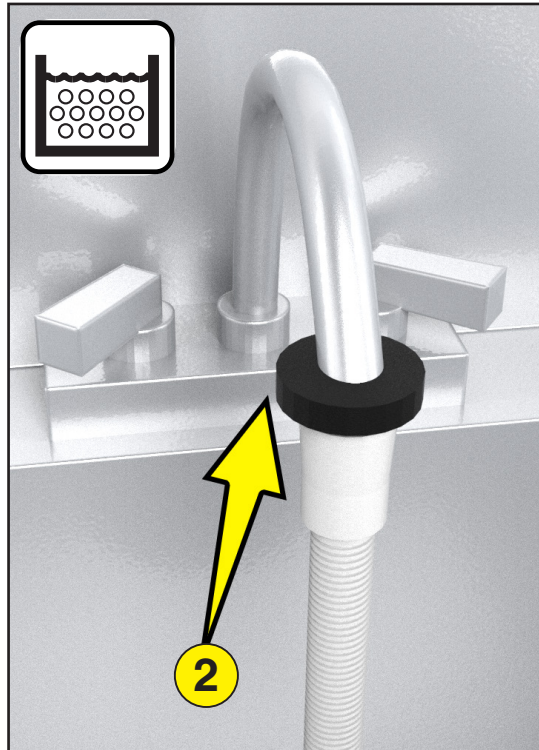
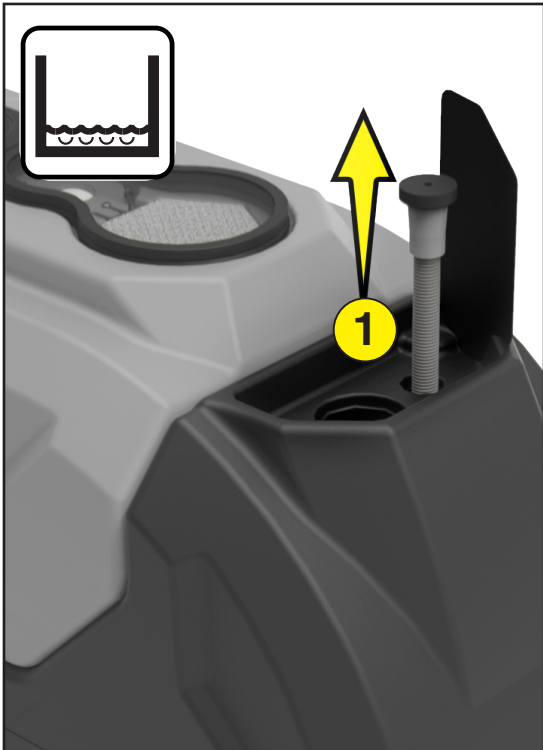
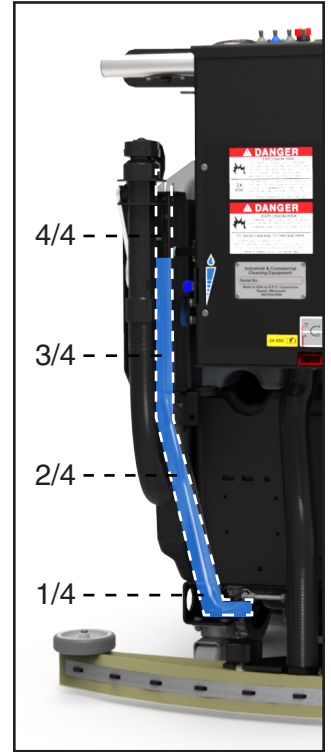
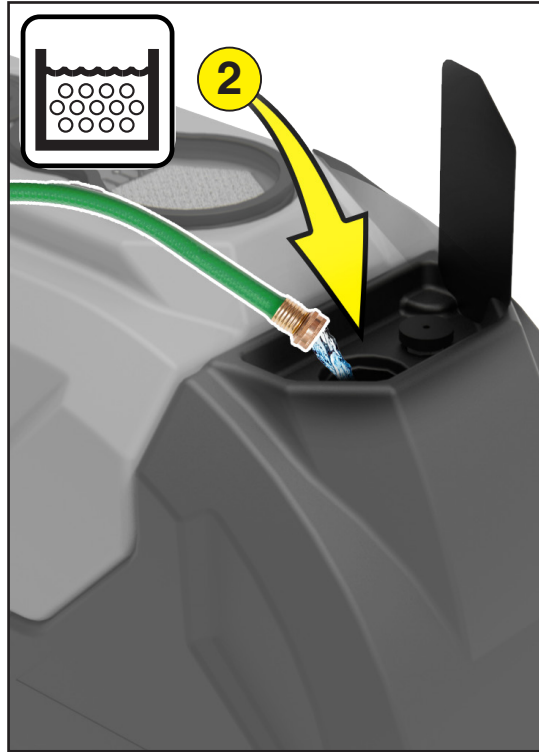
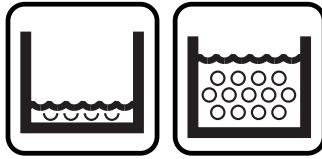

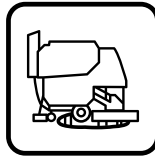

OPERATION

Scrubbing

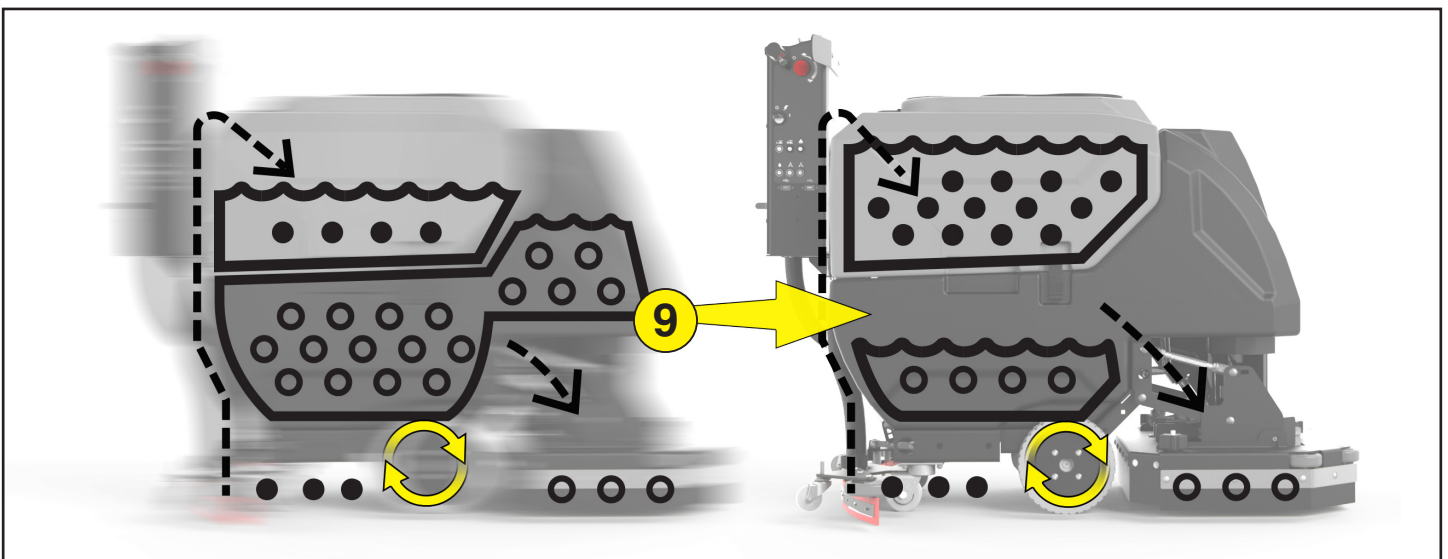
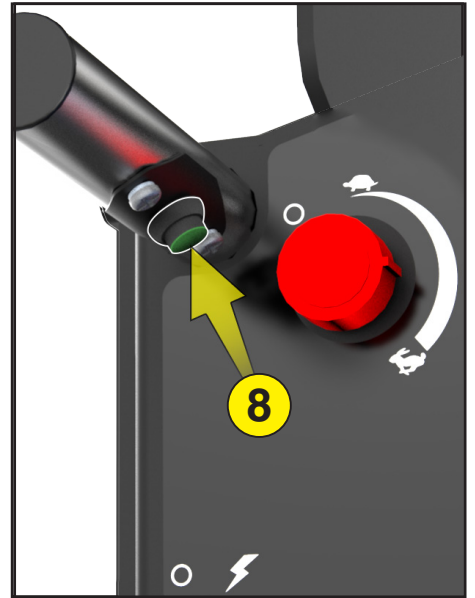
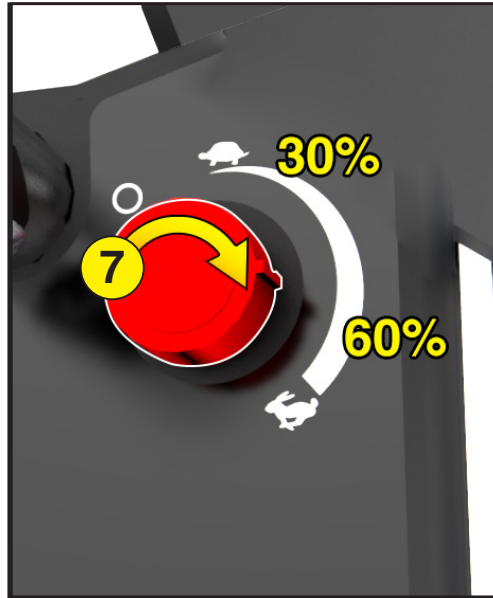
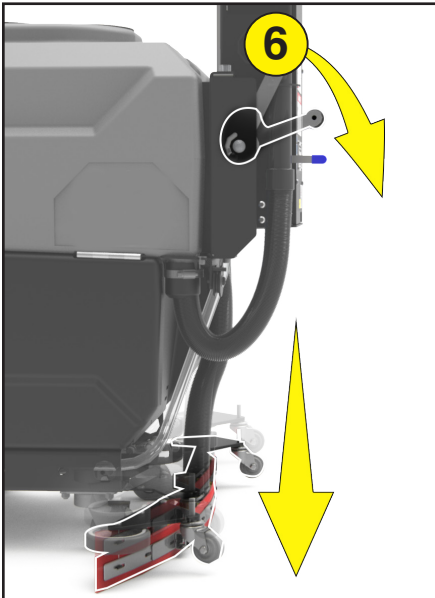
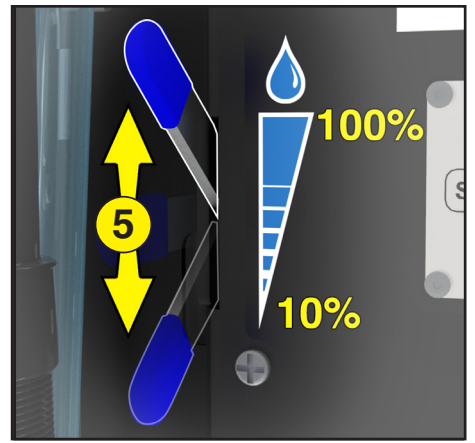
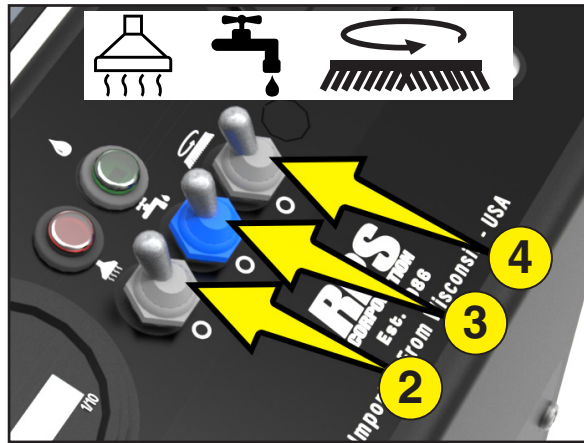

OPERATION

Drying

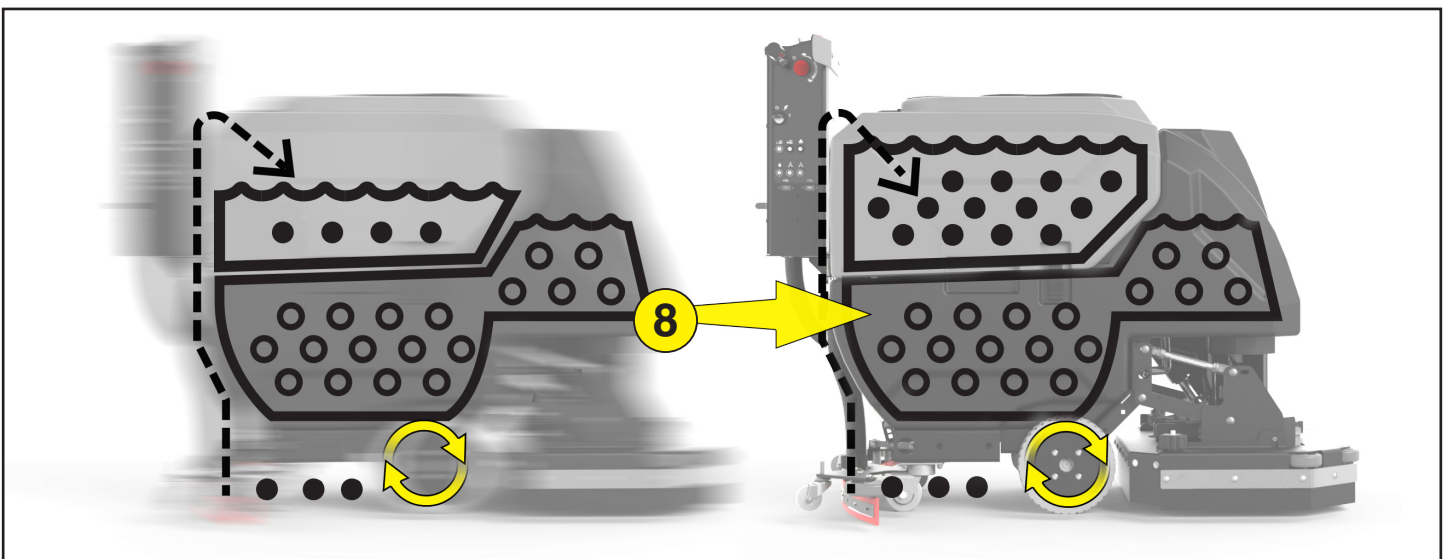
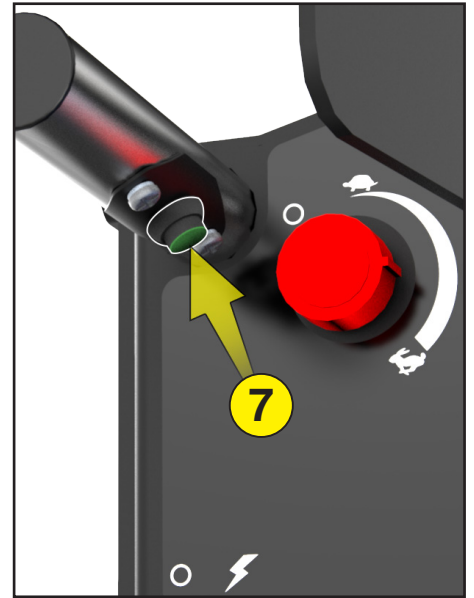
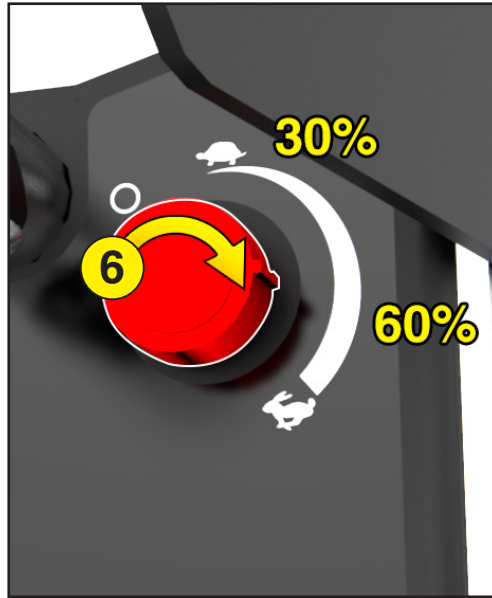
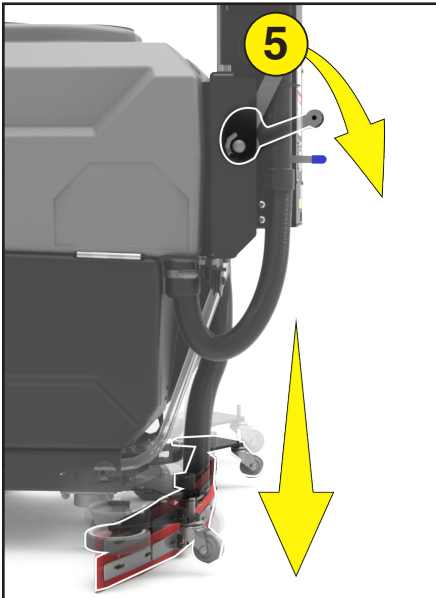
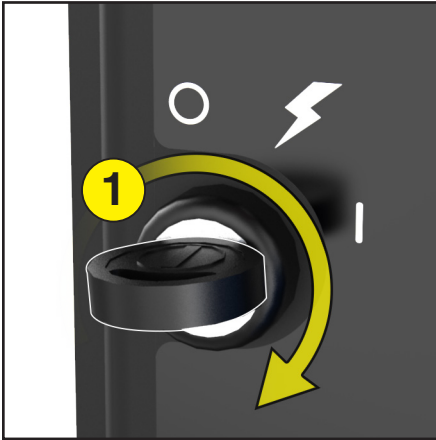
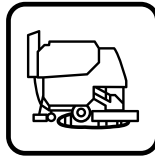



Drain Recovery Tank

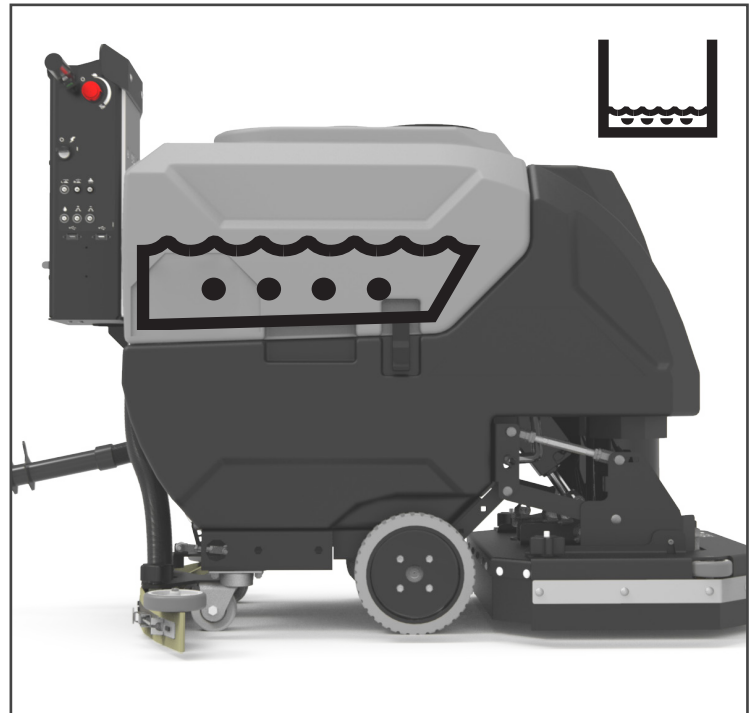
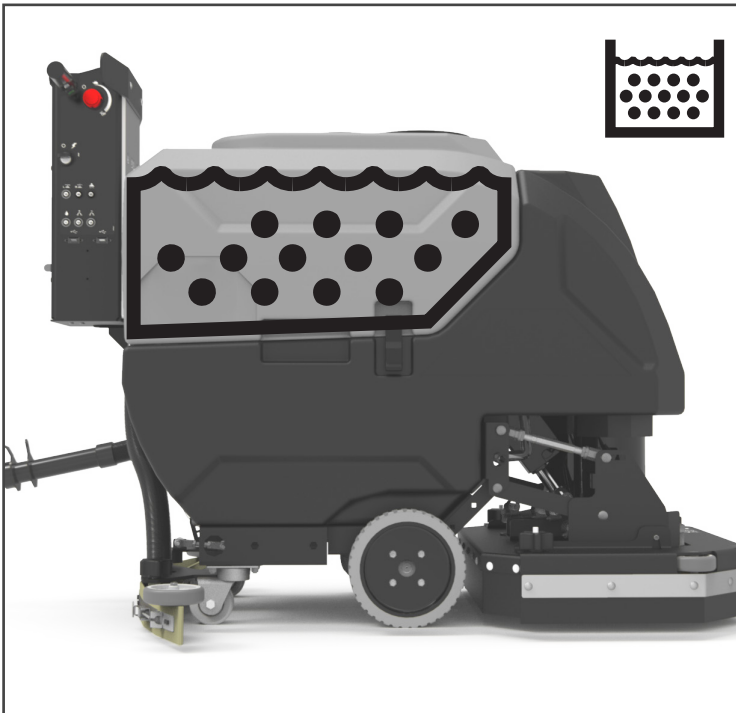
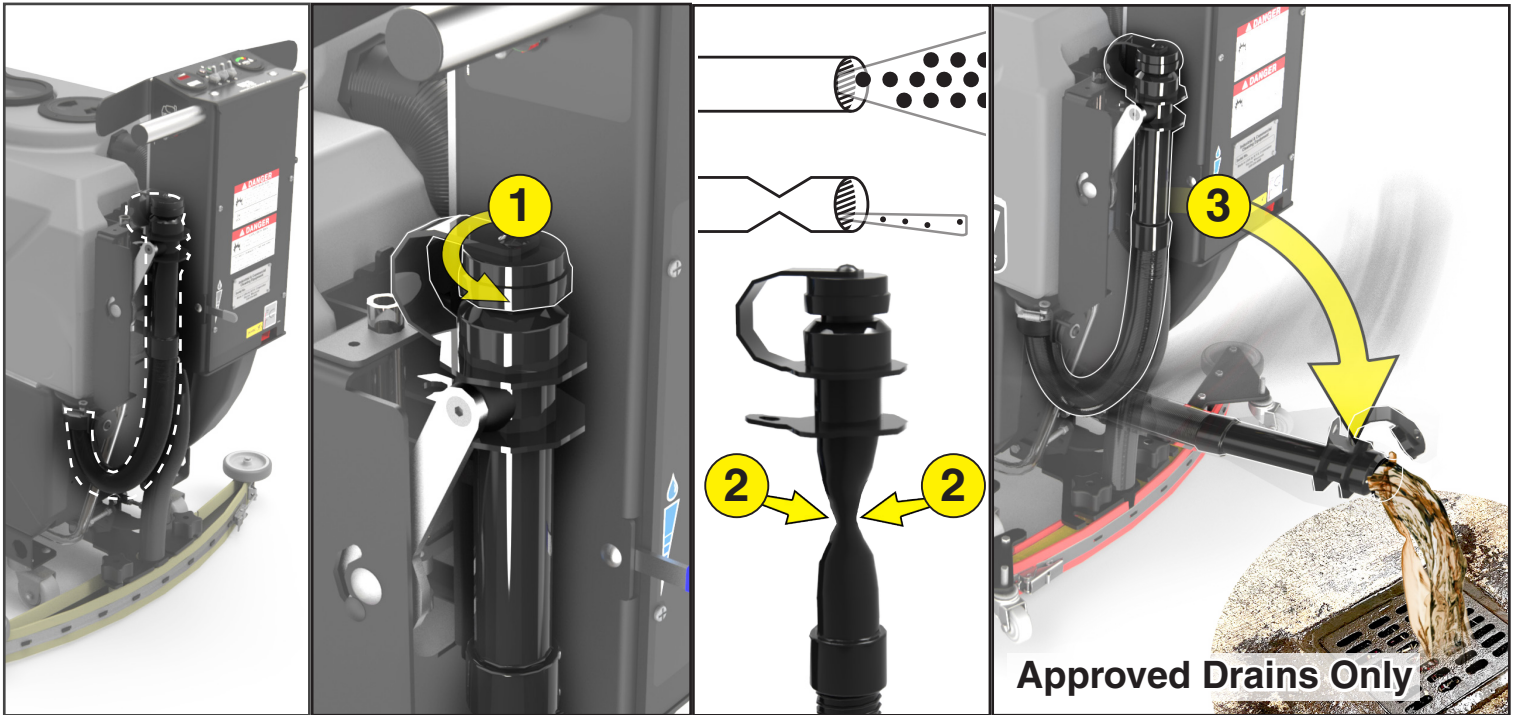

OPERATION

Flushing Recovery Tank

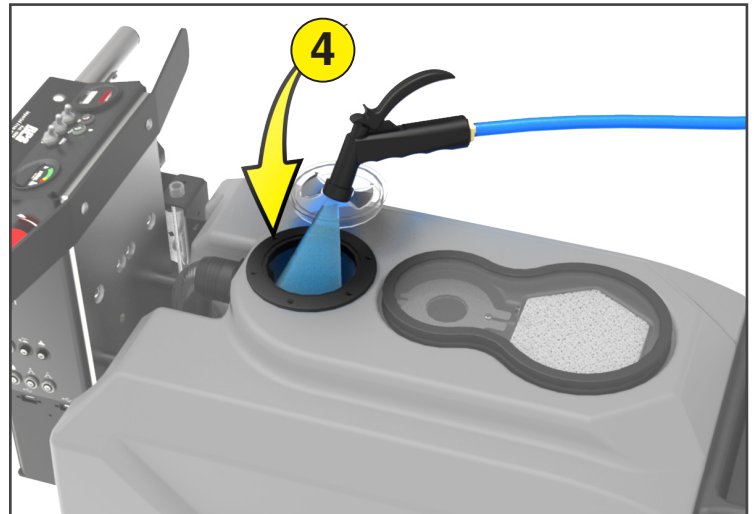
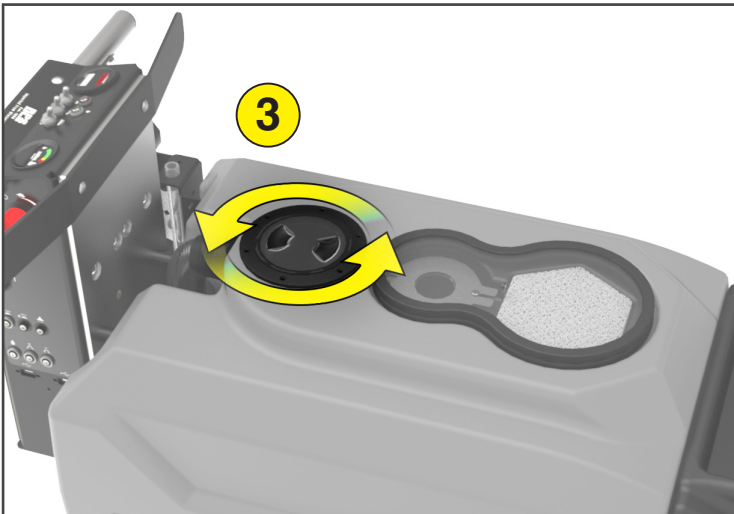
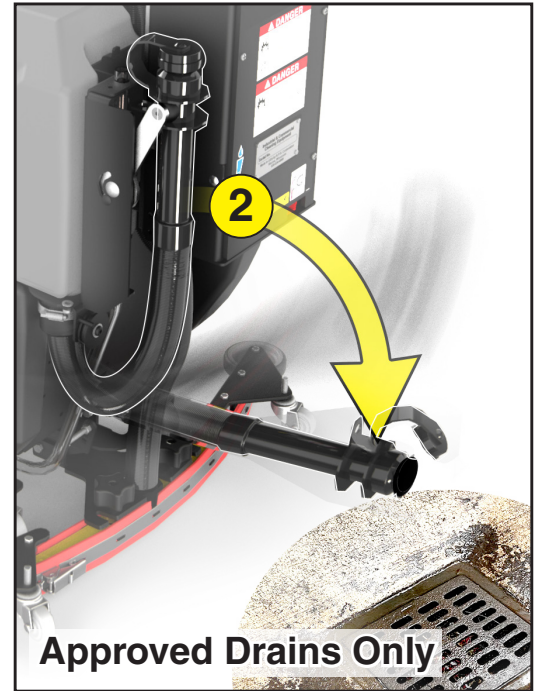
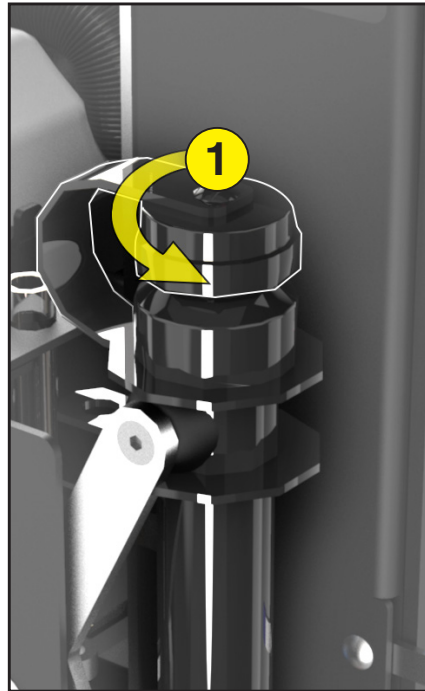
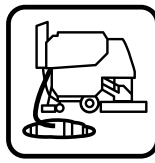

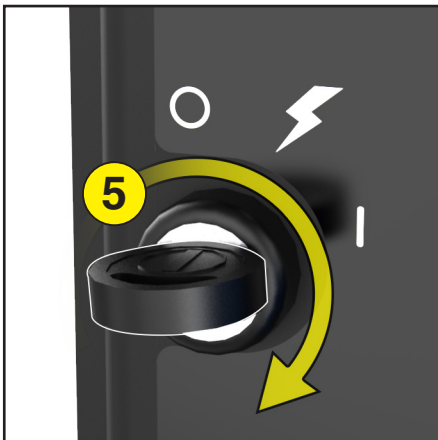
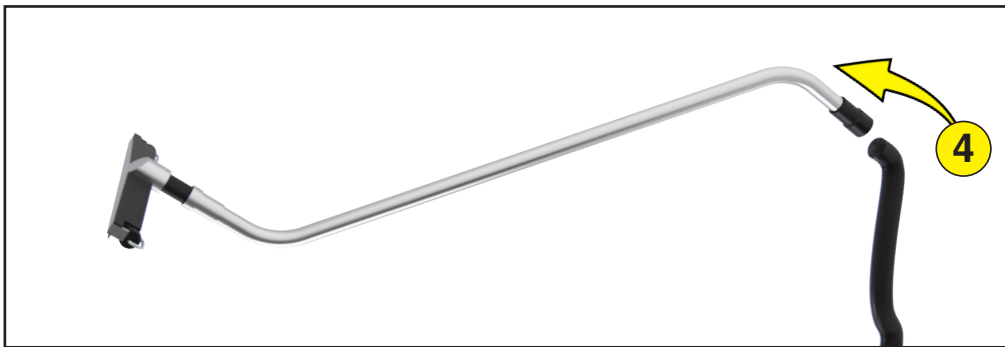
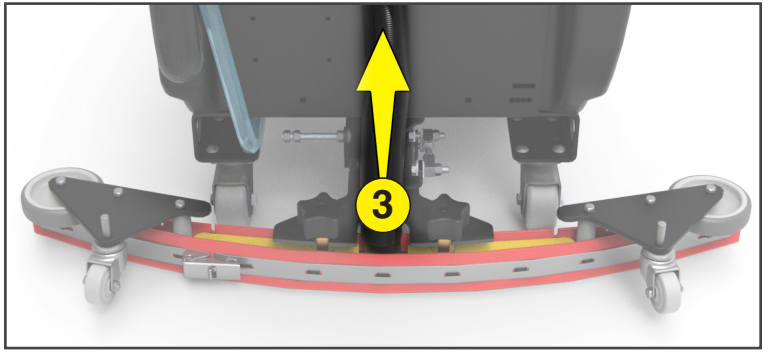
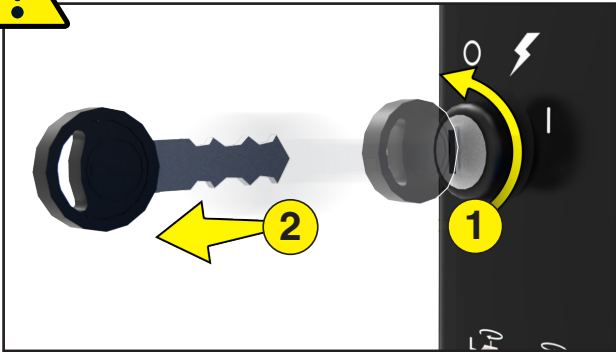

OPTIONS

Onboard Charger

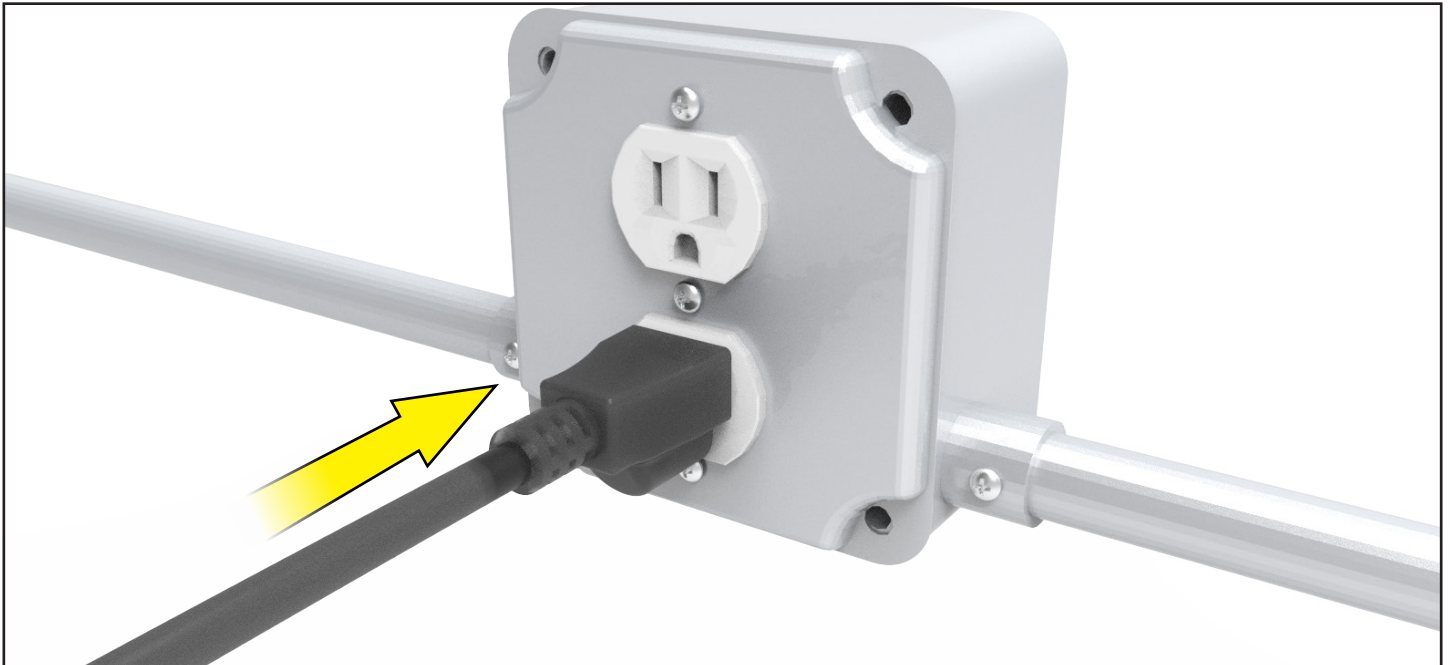
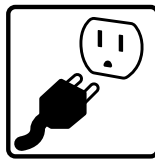



OPTIONS

Brush Pressure +/-

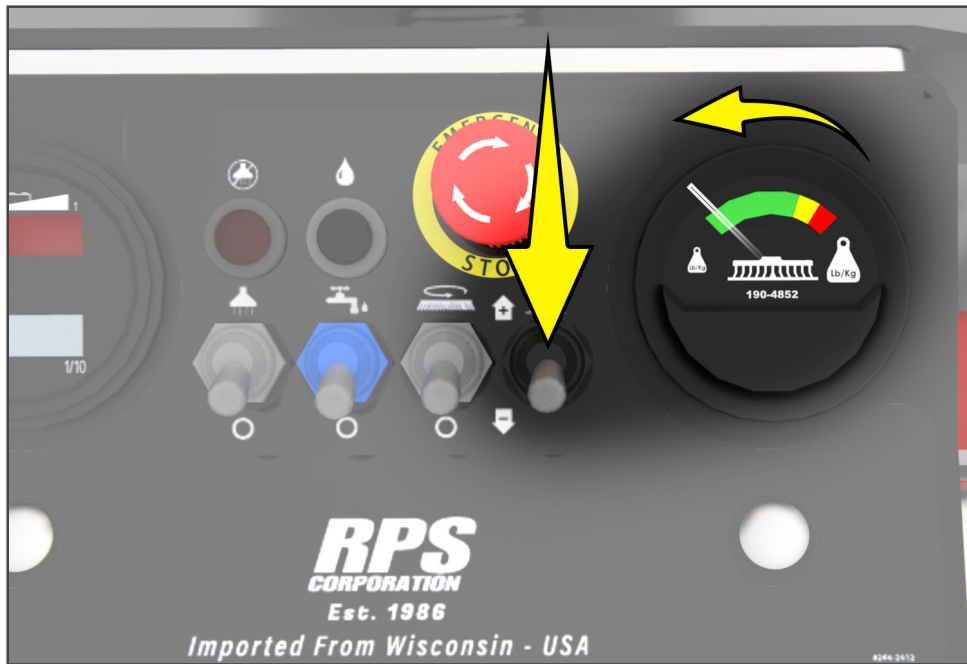
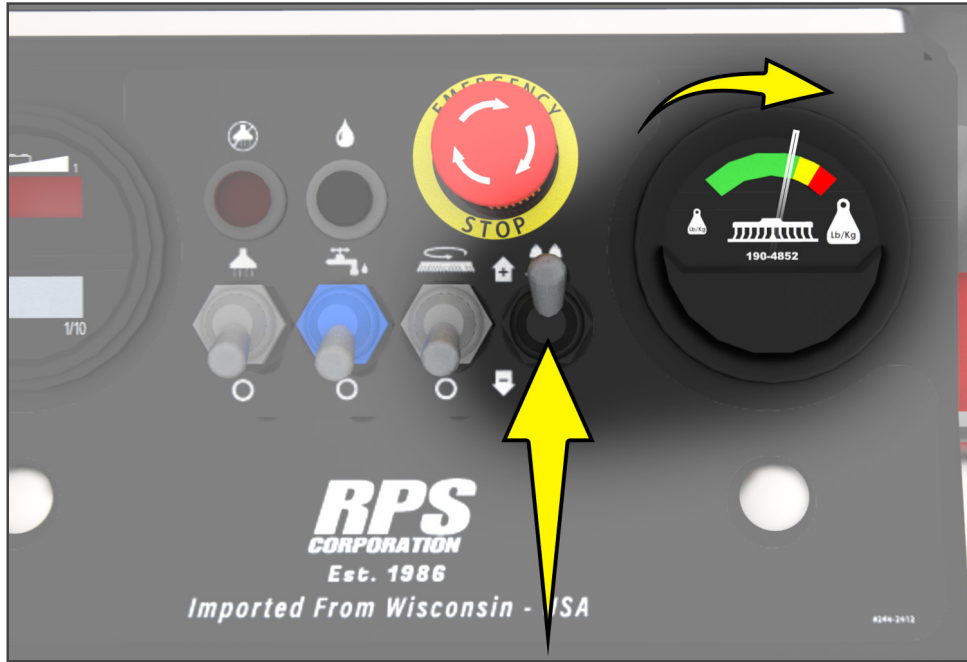

OPTIONS

Vac Clog Light

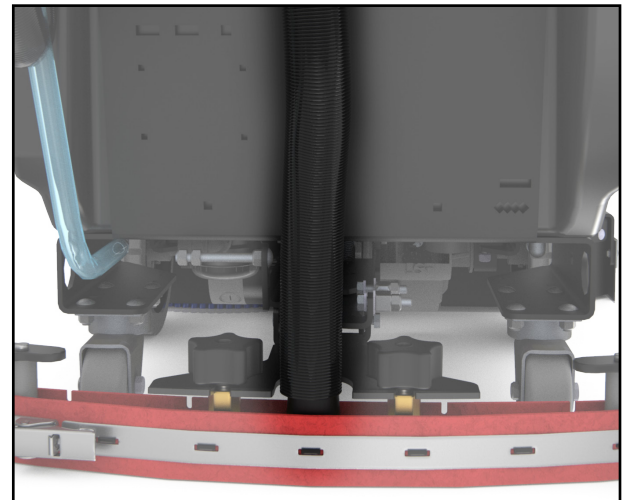
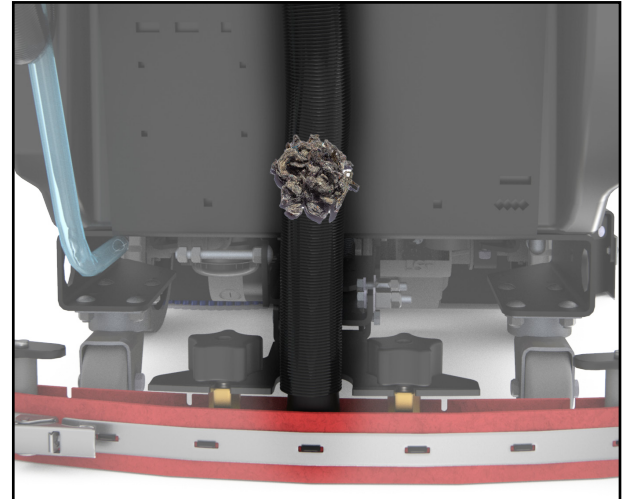

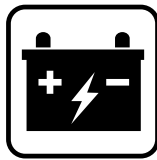

DAILY MAINTENANCE

Charge Batteries

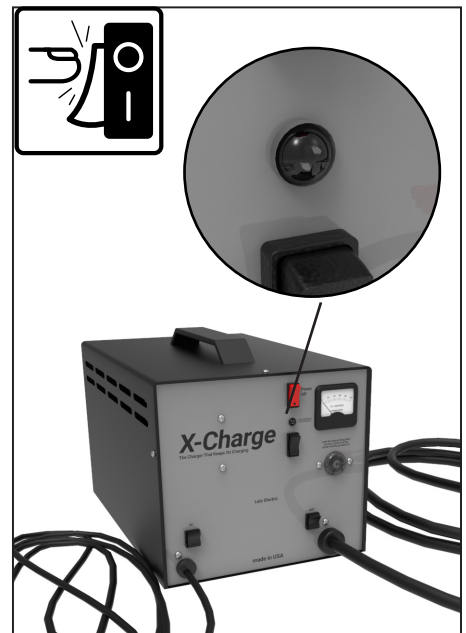
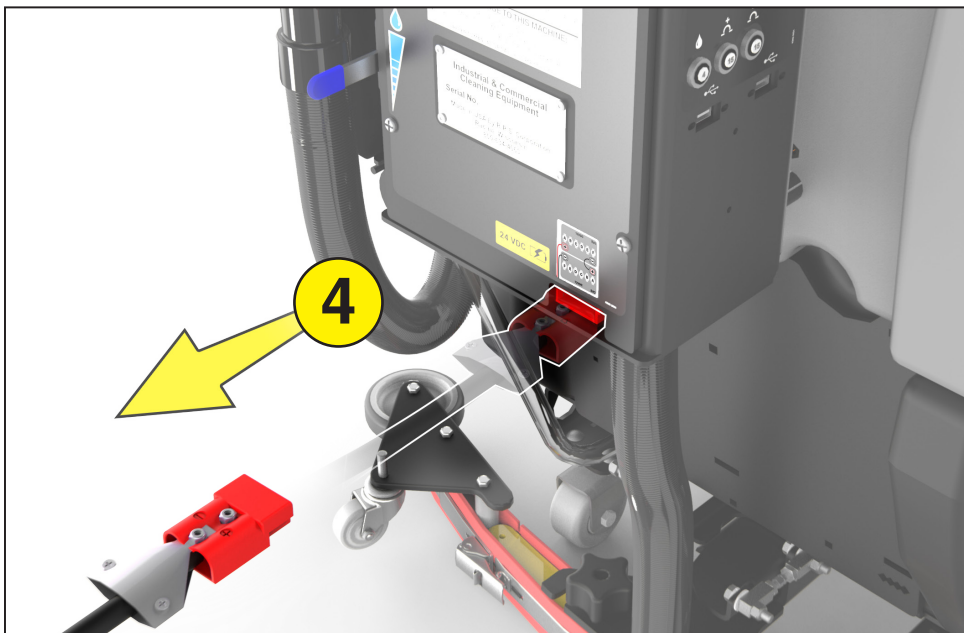
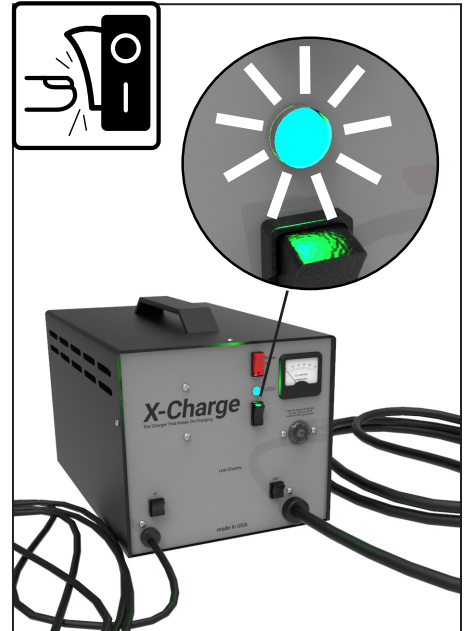
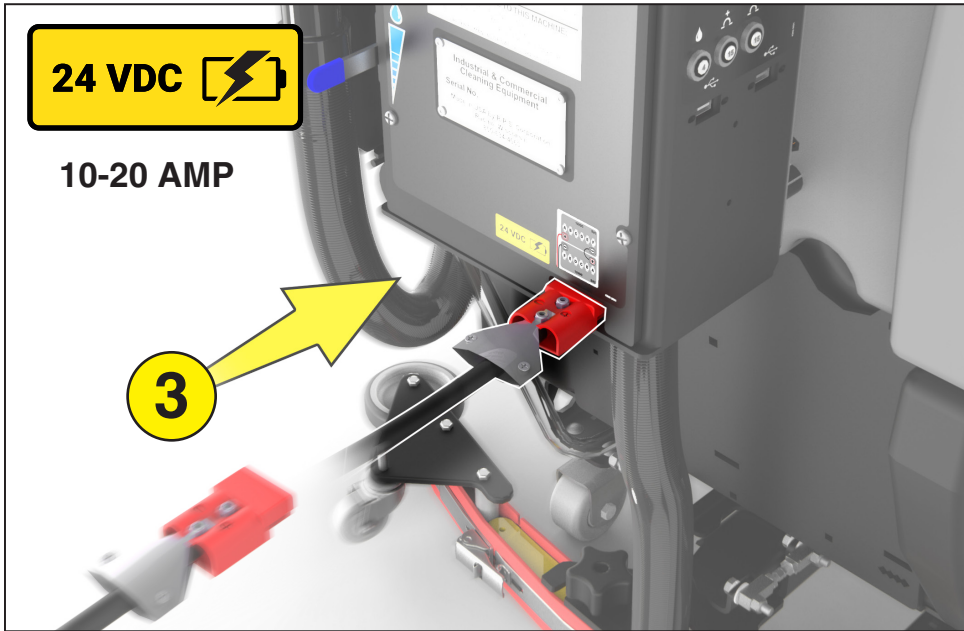
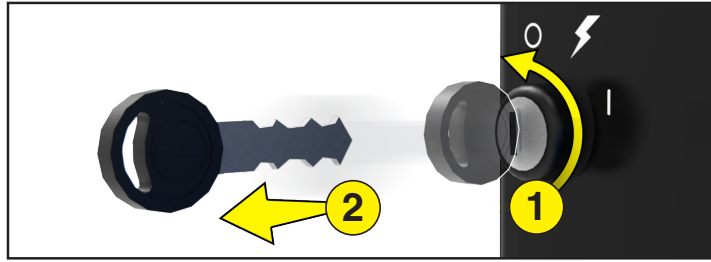

WEEKLY MAINTENANCE (<25 HRS)

Clean White Filter/Screen

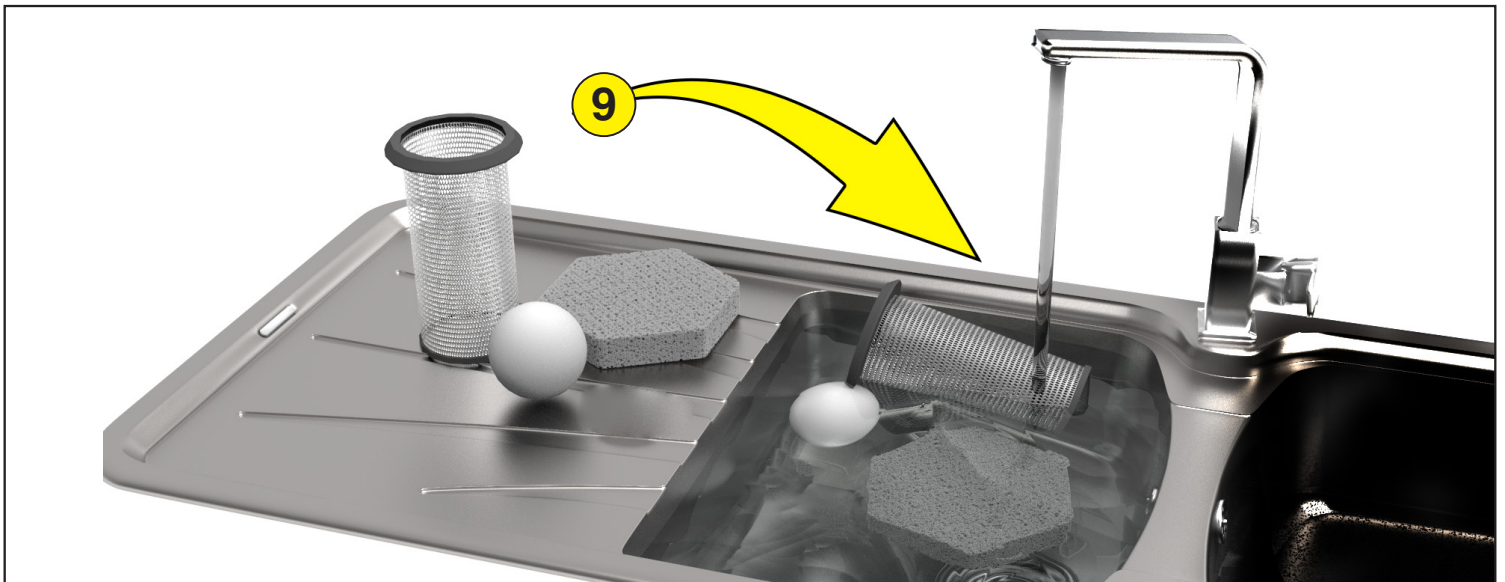
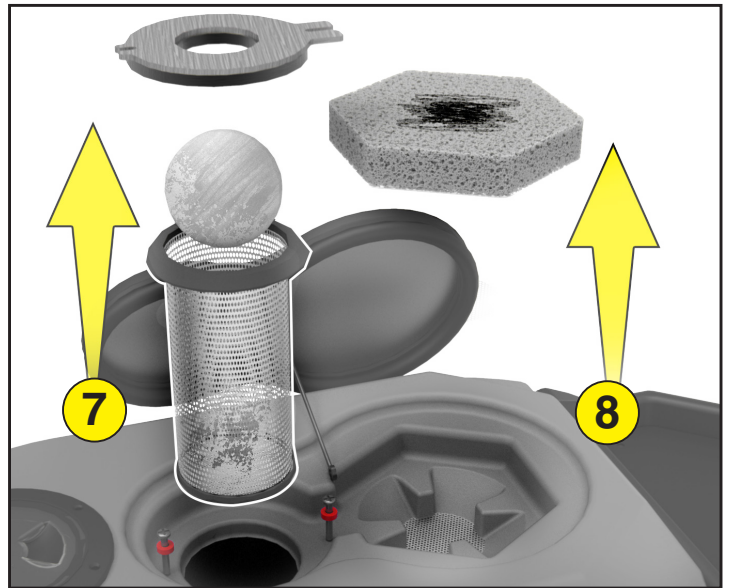
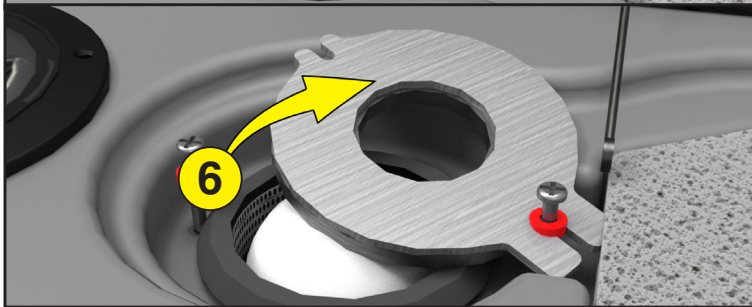
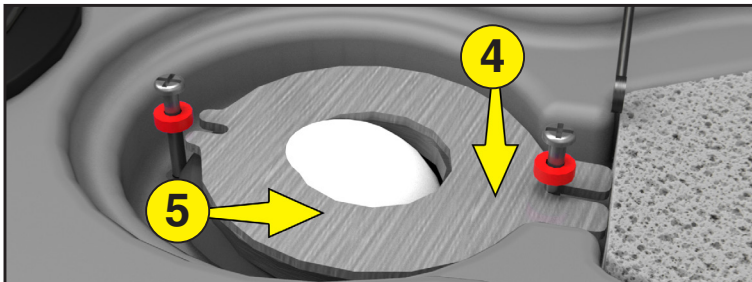
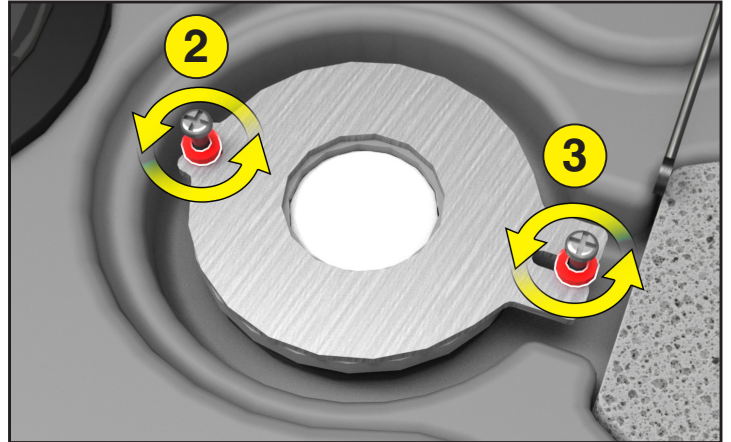
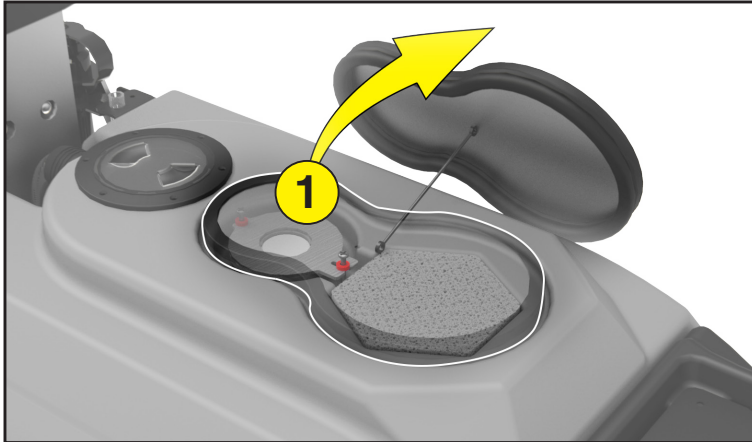
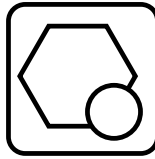



WEEKLY MAINTENANCE (<25 HRS)

Remove Disk Brushes

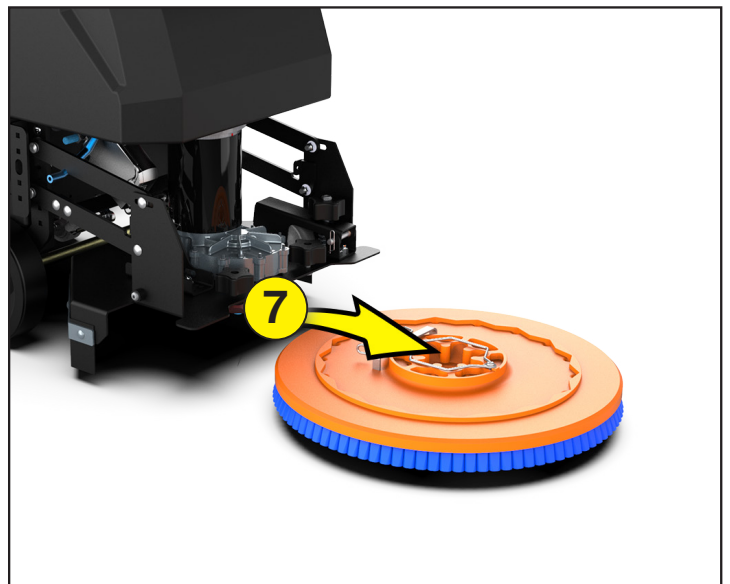
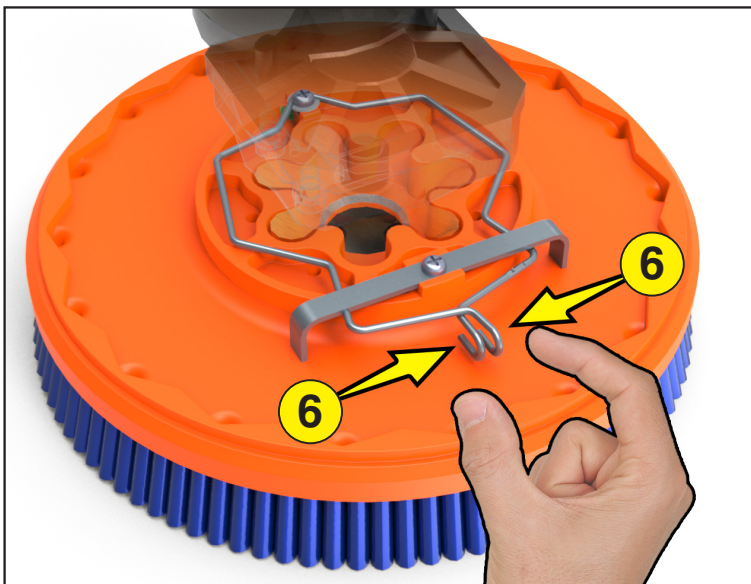
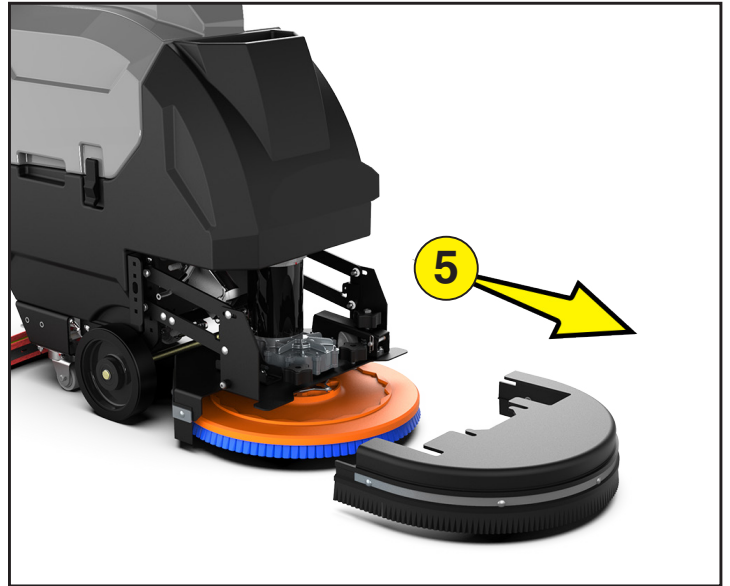
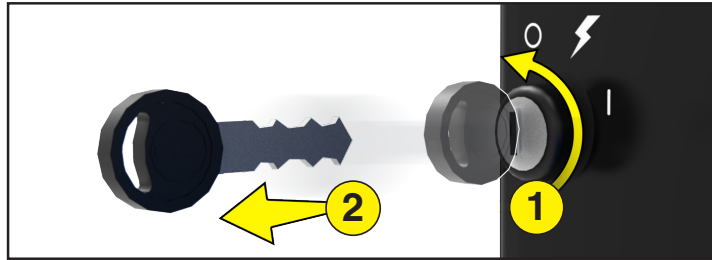

WEEKLY MAINTENANCE (<25 HRS)



Rotate Grout Brush

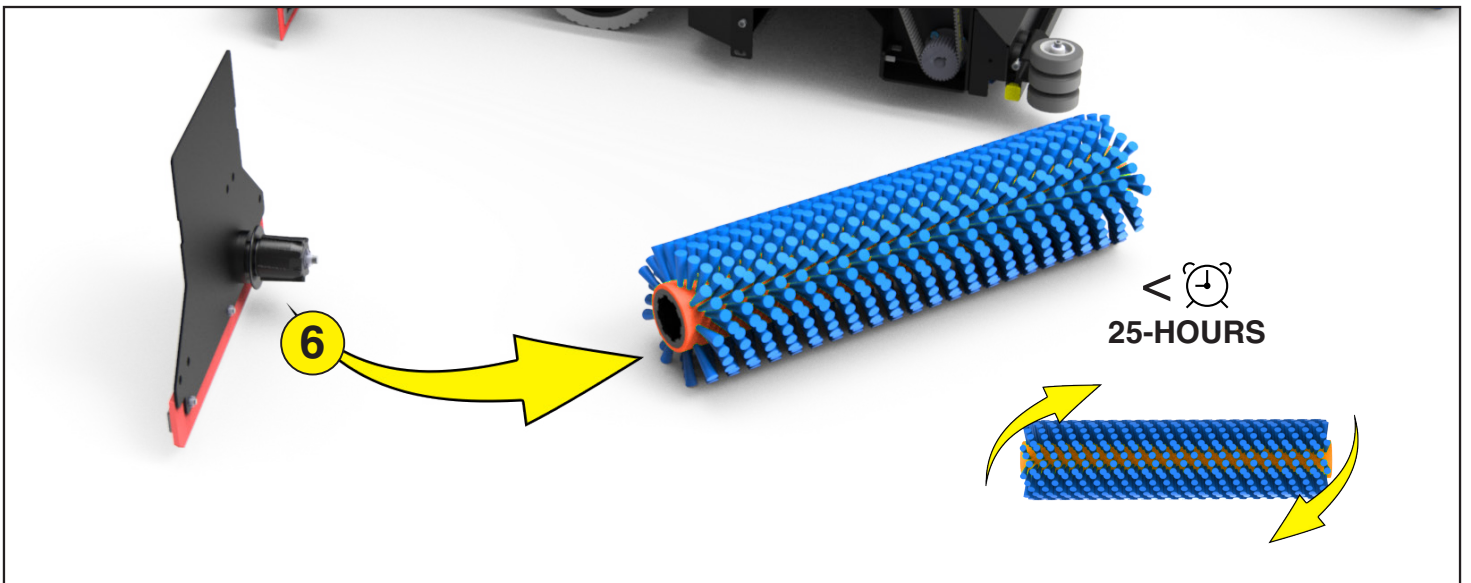
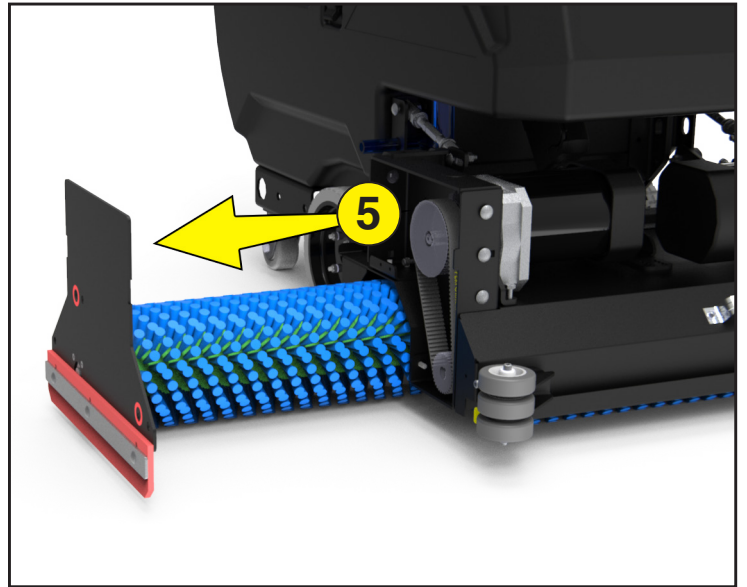
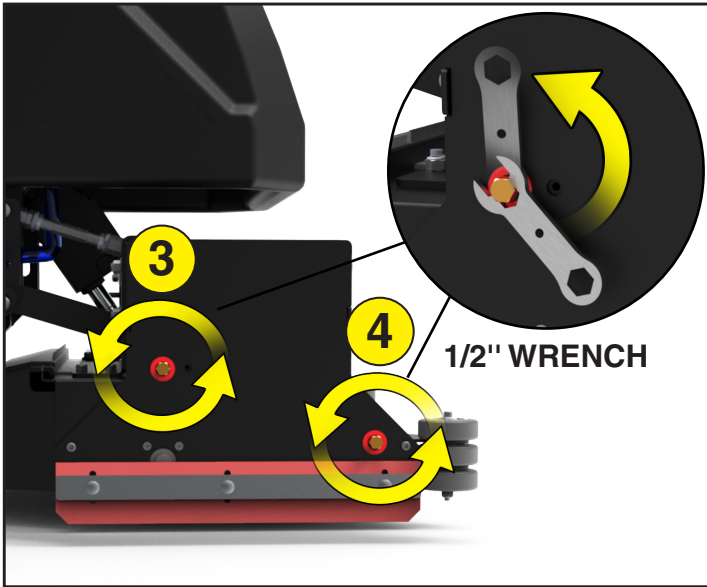
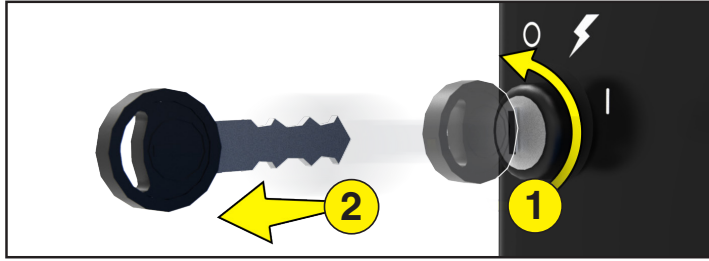



WEEKLY MAINTENANCE (<25 HRS)

Replace Orbital Pads

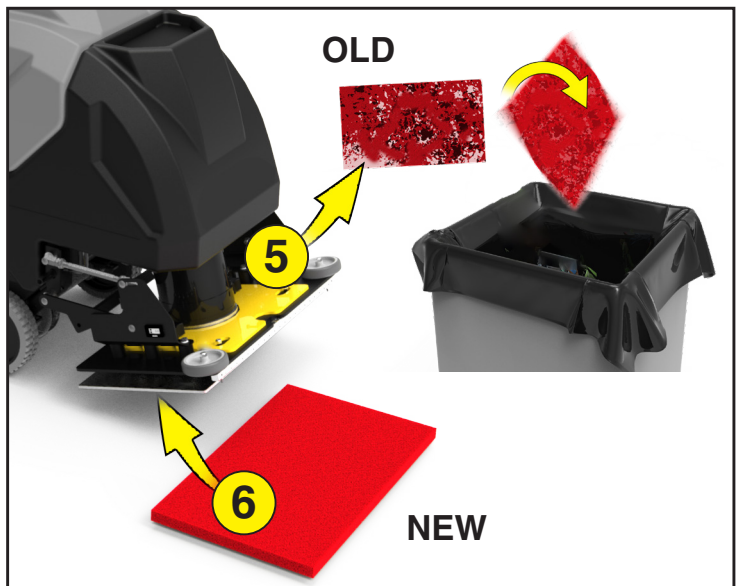
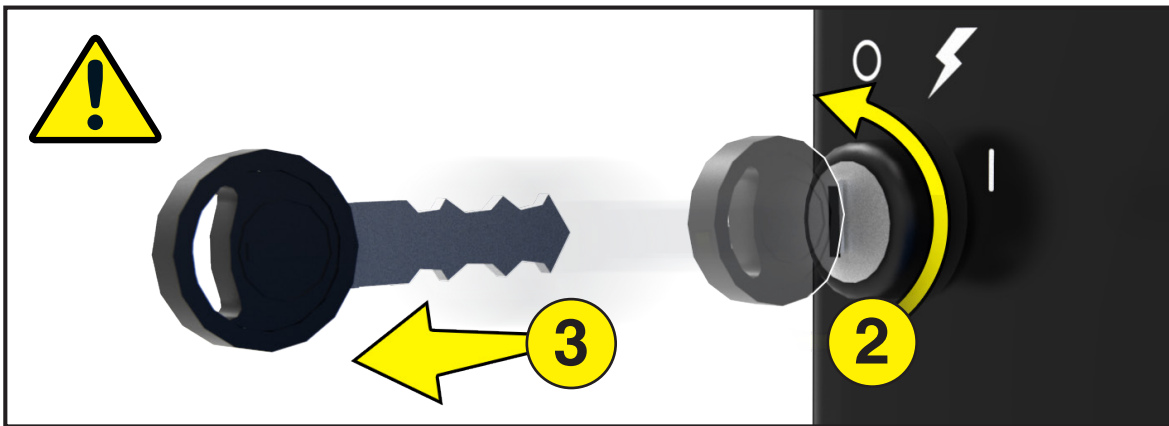
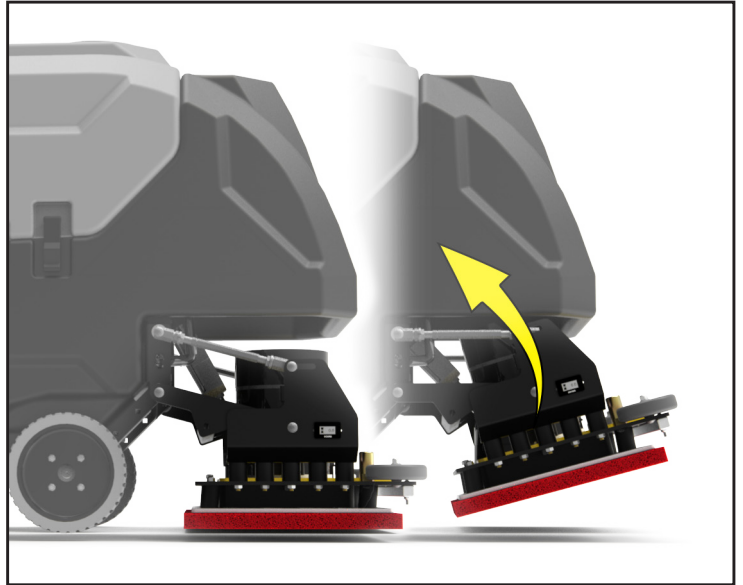

WEEKLY MAINTENANCE (<25

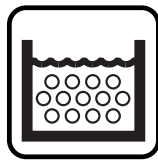

Clean Solution Filter

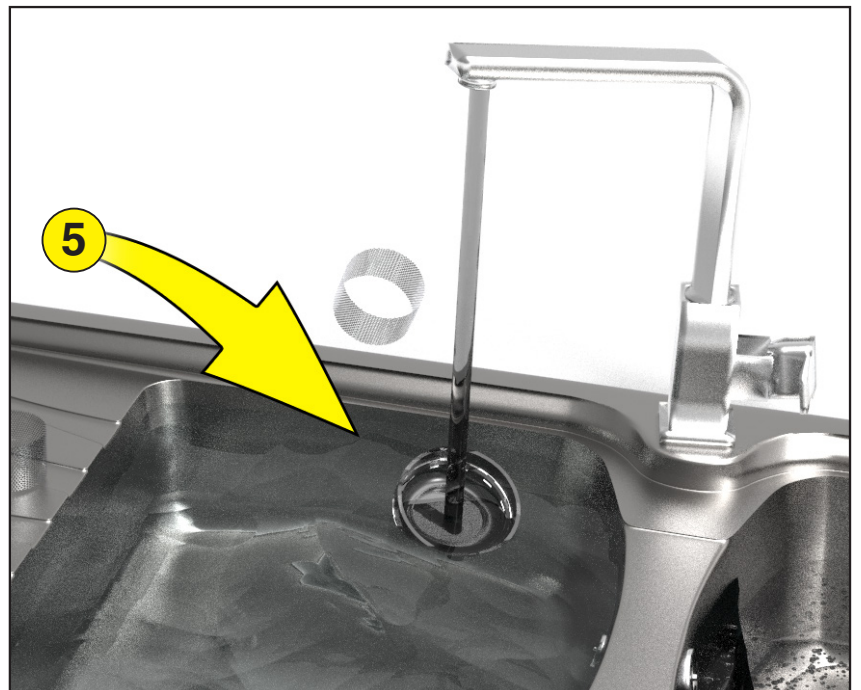
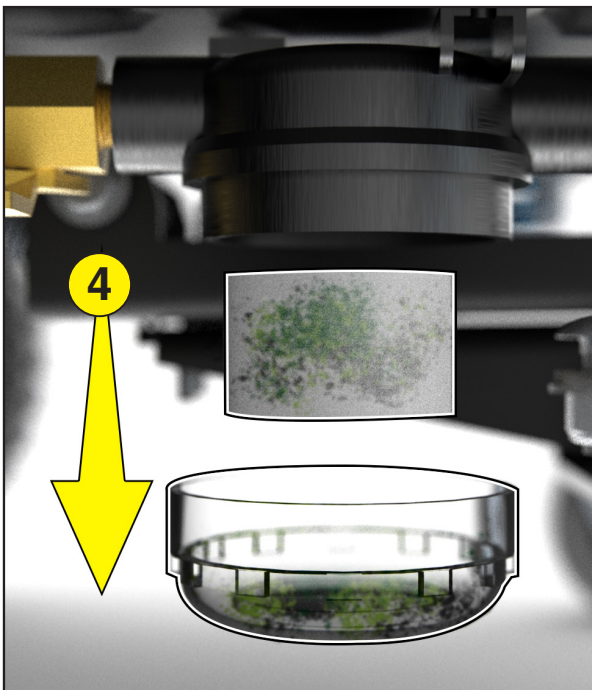
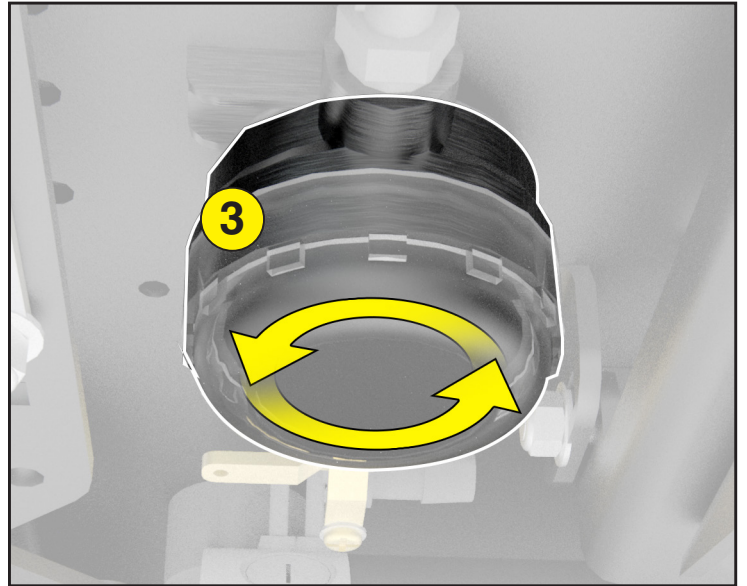
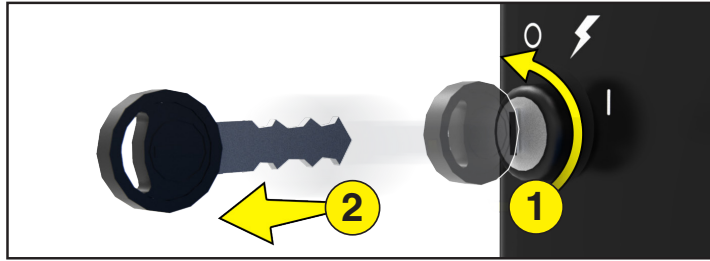

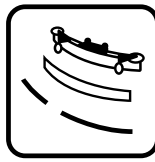

WEEKLY MAINTENANCE (<25 HRS)

Squeegee Blade Replacement

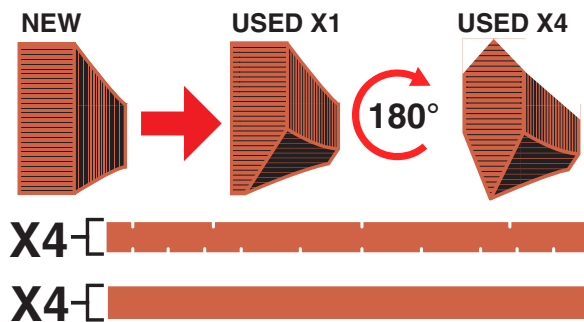
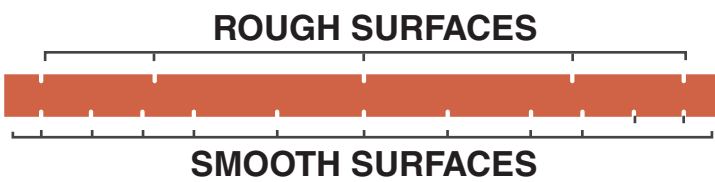
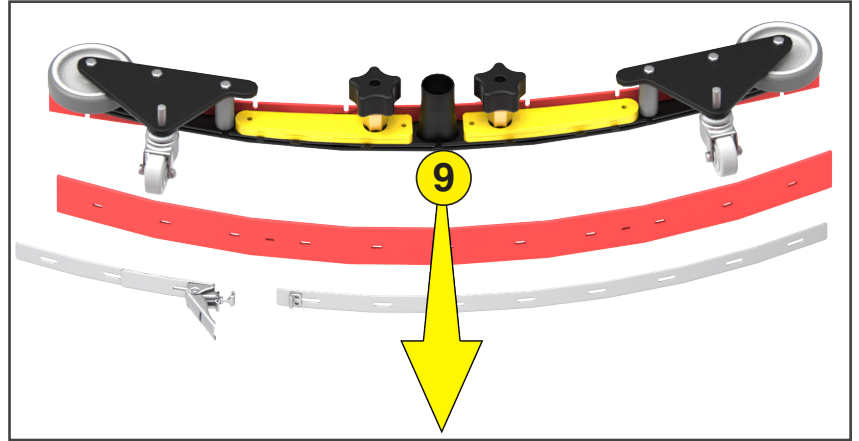
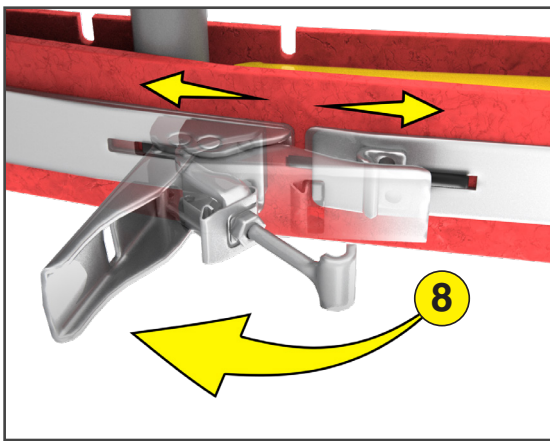
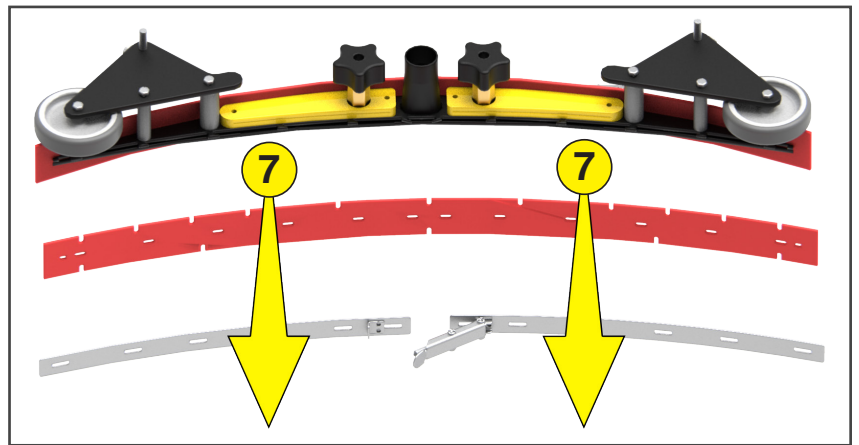
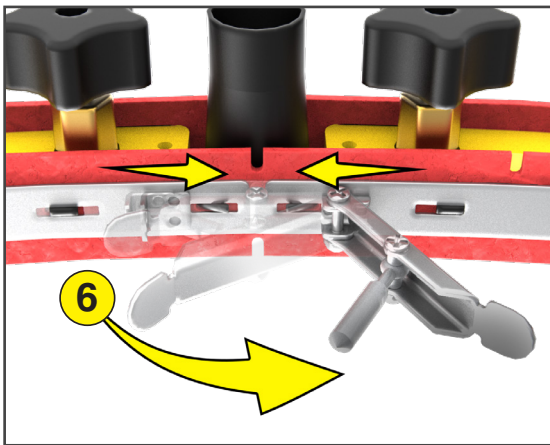
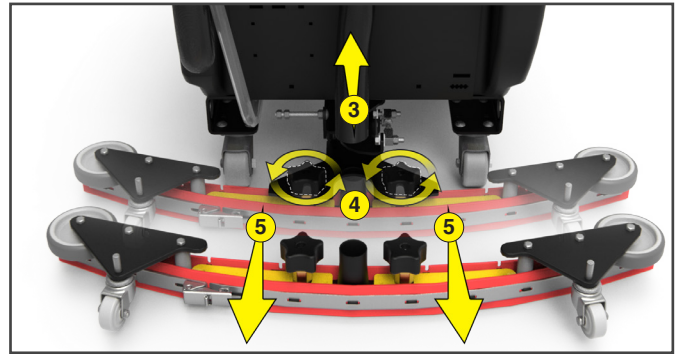
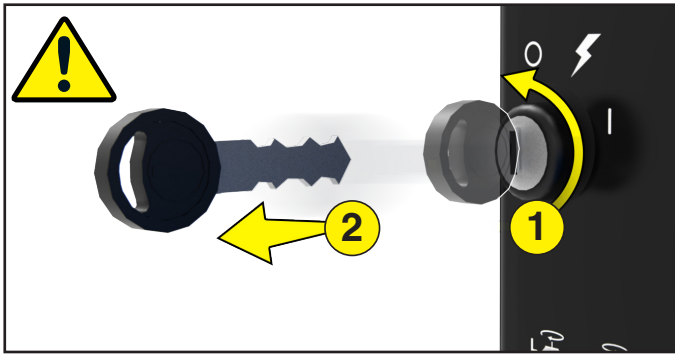

WEEKLY MAINTENANCE (<25 HRS)

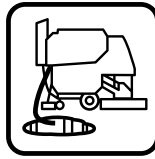

Drain Solution Tank

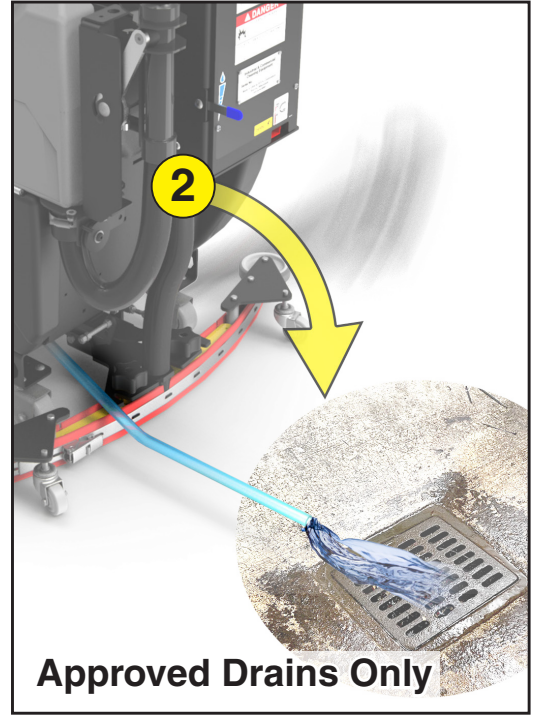
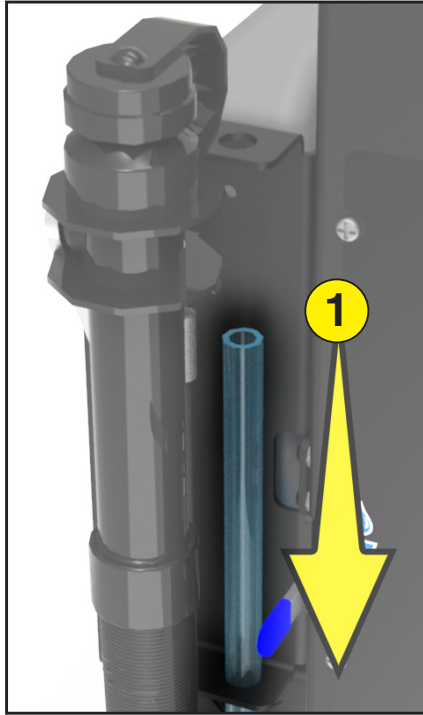

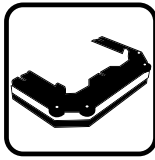

MONTHLY MAINTENANCE (<100 HRS)

Deck Shroud Curtain Replacement

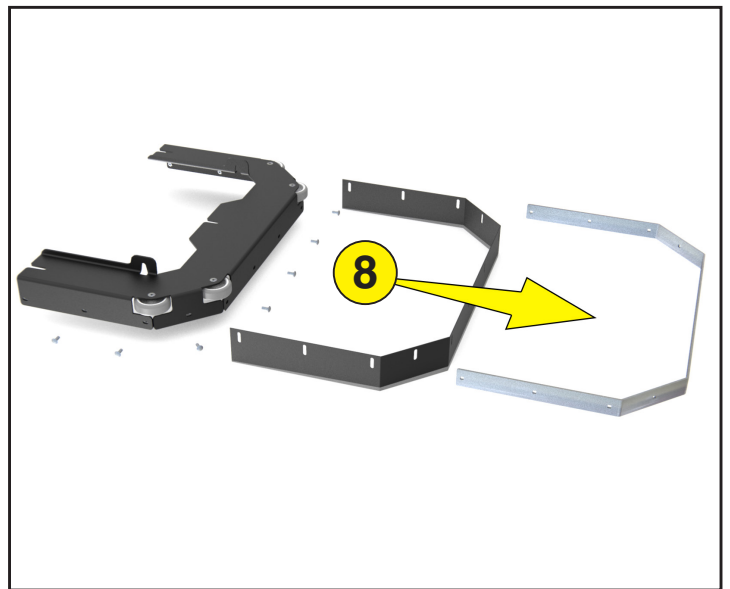
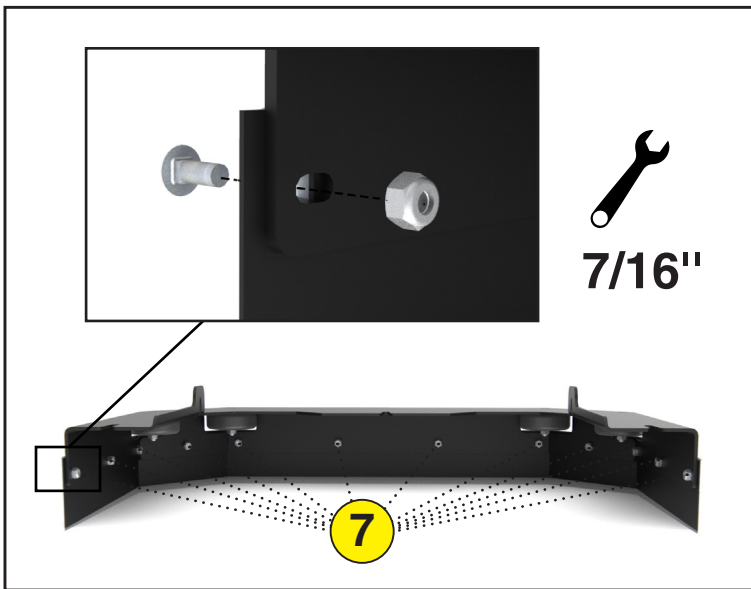
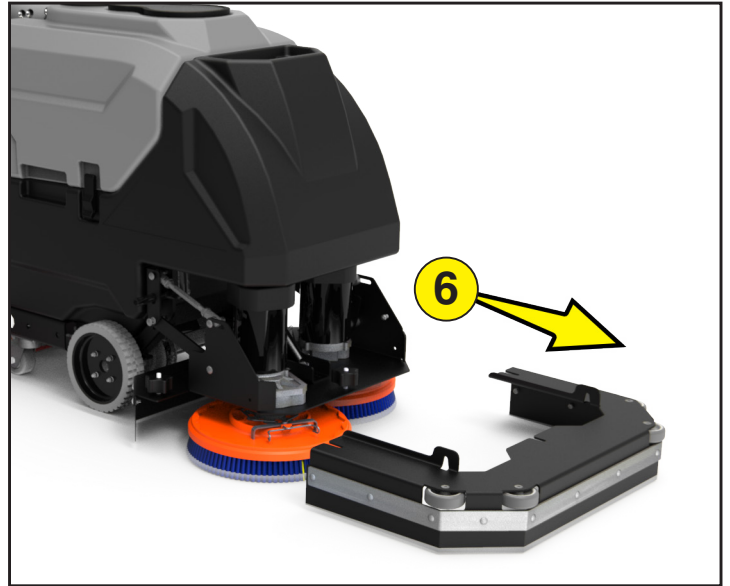
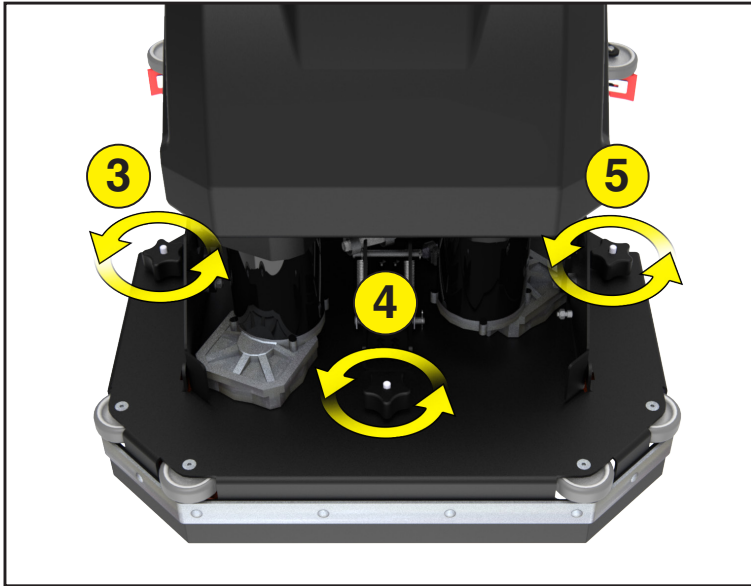
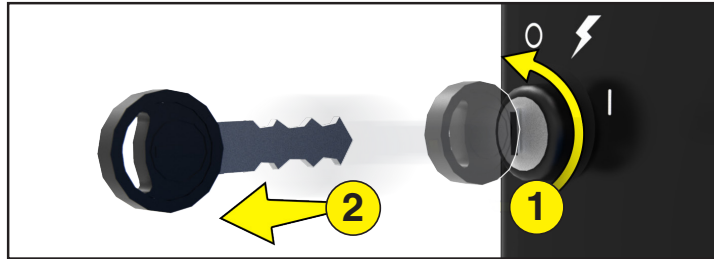



Grout Side Wiper Replacement

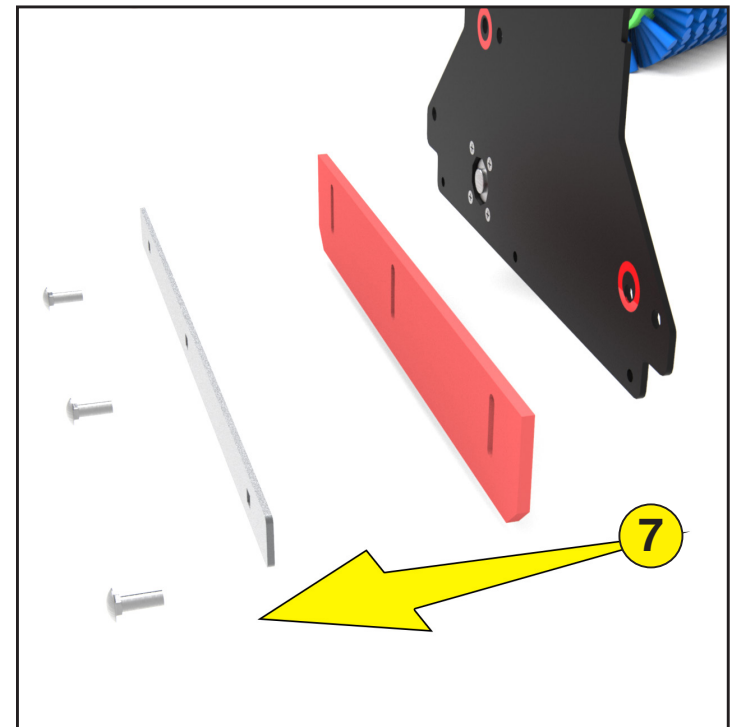
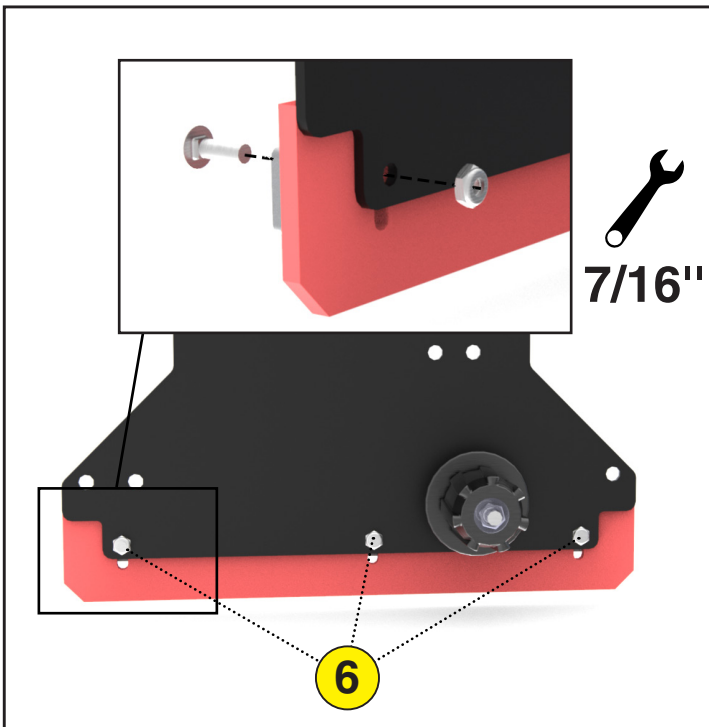
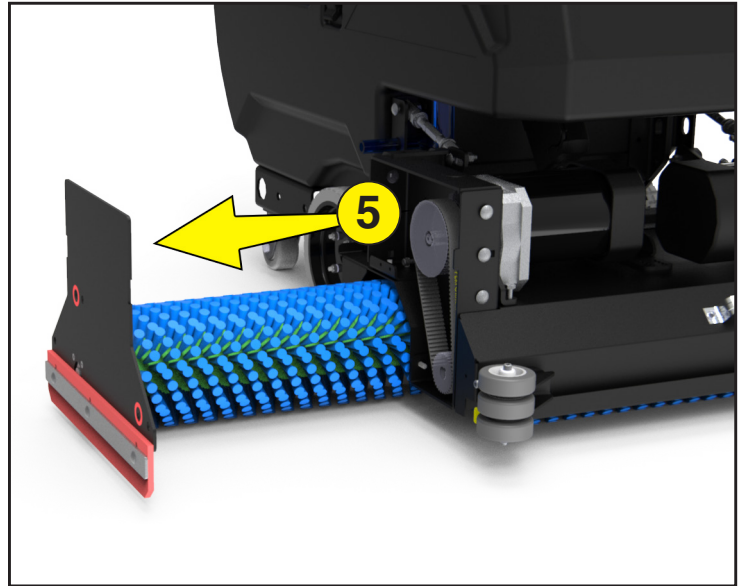
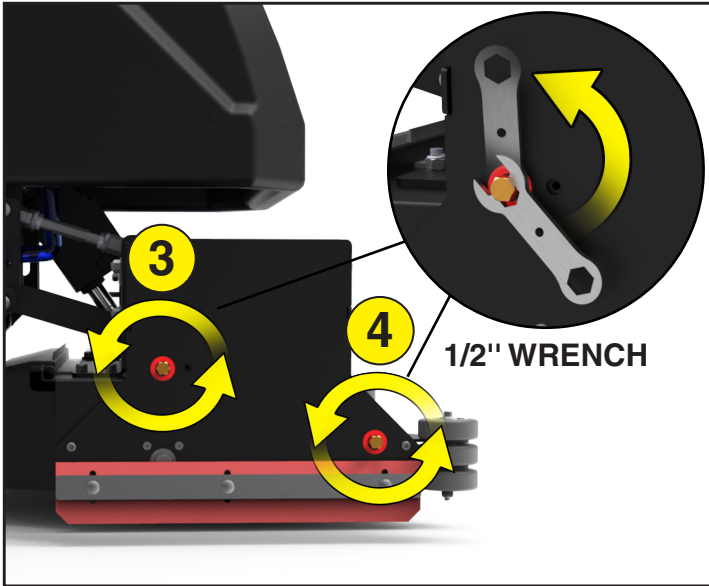
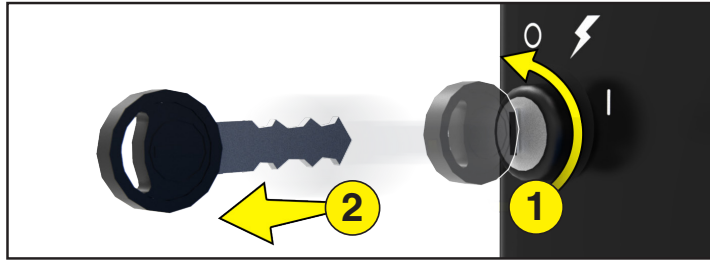

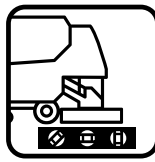

MONTHLY MAINTENANCE (<100 HRS)

Deck Leveling

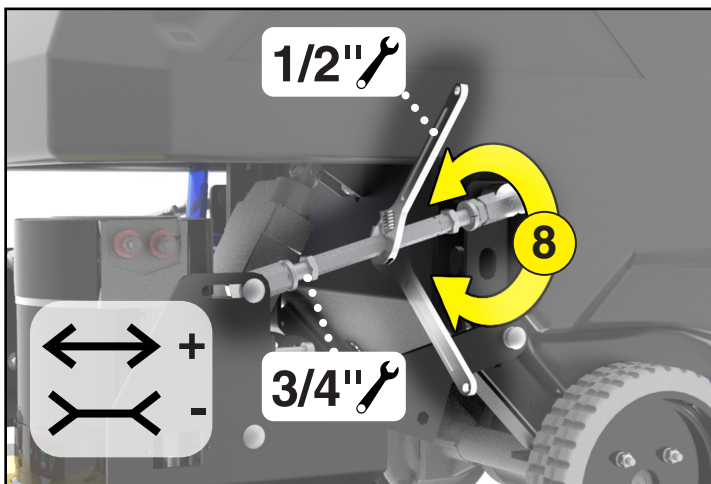
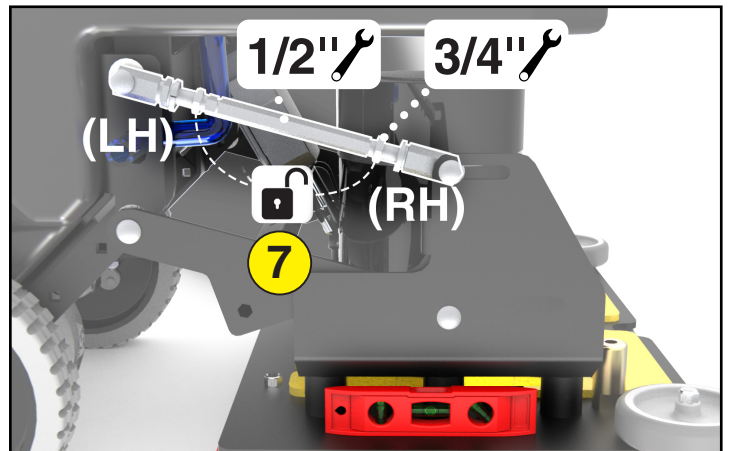
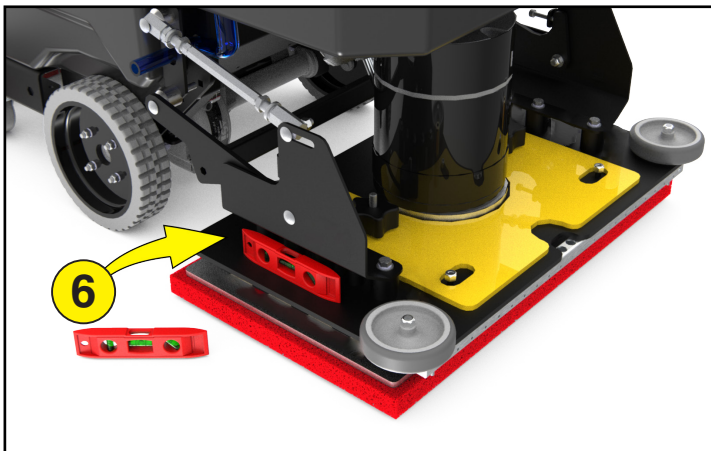
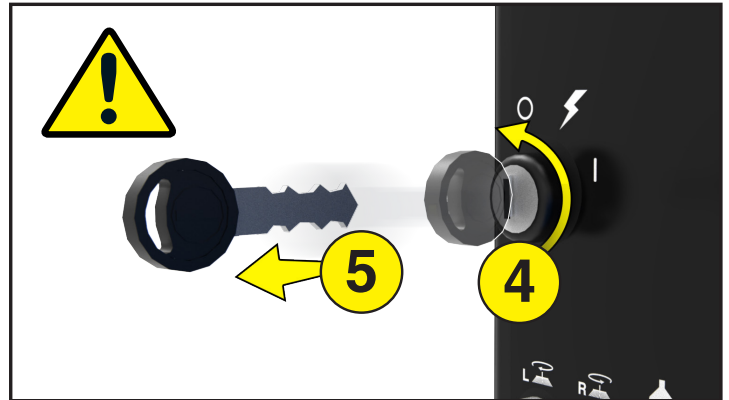
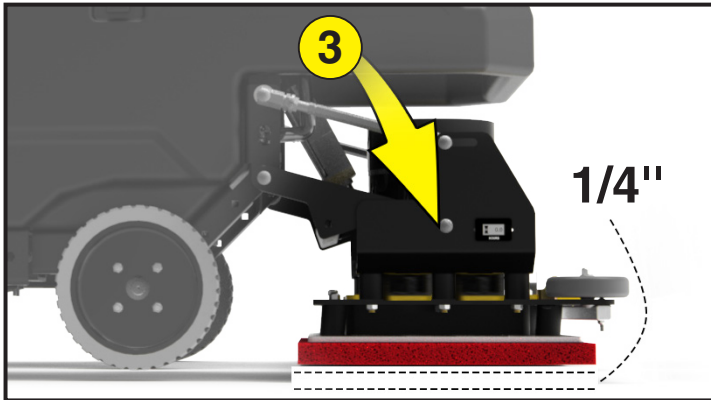
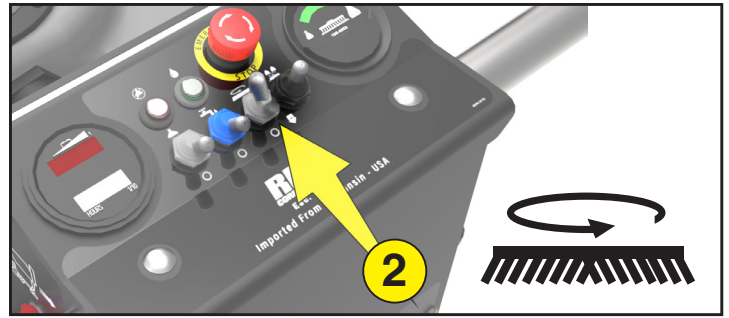
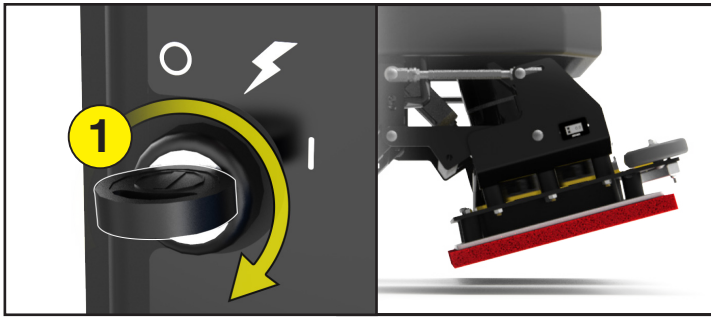

OTHER

Common Wear Parts

EDGE PADS AND SCREENS:

DESCRIPTION	20"×14" SCRUBDECK	24"×14" SCRUBDECK
White Pad	EDGE-4005	N/A
Red Pad	EDGE-4004	EDGE-2404
Blue Pad	EDGE-4003	EDGE-2403
Green Pad	EDGE-4002	EDGE-2402
Black Pad	EDGE-4001	EDGE-2401
White Driver Pad	EDGE-4025	N/A
60 Grit Sand Screen	N/A	N/A
80 Grit Sand Screen	N/A	N/A
100 Grit Sand Screen	N/A	N/A
120 Grit Sand Screen	N/A	N/A
150 Grit Sand Screen	N/A	N/A
400 Grit HD Non Woven Polishing Pad	N/A	N/A
800 Grit HD Non Woven Polishing Pad	N/A	N/A
1500 Grit HD Non Woven Polishing Pad	N/A	N/A
3000 Grit HD Non Woven Polishing Pad	N/A	N/A
6000 Grit Diamond Poly Pad	N/A	N/A
Tile/Grout Renovator Pad	EDGE-4069	N/A
Dominator HD Strip Pad	EDGE-4006	N/A
Maroon ECO Prep Pad	EDGE-4007	EDGE-2407
Microfiber Pad	EDGE-4036	EDGE-2436

Common Wear Parts

ROUND DISK BRUSHES:**NOTICE**

The ## in Disk Column Denotes Desk Pad Size: 17" or 20"

BRUSHES	DISK	LEVEL
Midi Grit	706-##C	Medium
Light Grit	706-##PS	Moderate
Nylon	706-##N	Light
Pad Driver	706-##D	
Pad Driver Pad Retainer	#40-433	
Pad Driver Spring Clip	#40-423	

ROUND DISK PADS:**NOTICE**

The ## in Disk Column Denotes Desk Pad Size: 17" or 20"

DISK PADS	DISK	LEVEL	COLOR
Super Black	##-422BB	Very High	Black
Black	##-422B	High	Black
Brown	##-422BR	High	Brown
Green	##-422G	Medium	Green
Blue	##-422BL	Moderate	Blue
Red	##-422R	Moderate	Red
White	##-422W	Light	White

CYLINDRICAL BRUSHES:

BRUSHES	MODEL 26" CYLINDRICAL	LEVEL
Midi Grit	75-246C	Medium
Light Grit	75-246PS	Moderate
Nylon	75-246N	Light

OTHER

Squeegee Blade Kits

SQUEEGEE BLADE KITS & COMPLETE SQUEEGEE ASSEMBLIES:

SQUEEGEE SIZE	17" DECK	20" DECK	24" DECK
31" Squeegee	Standard	N/A	N/A
33" Squeegee	N/A	Standard	N/A
37" Squeegee	N/A	N/A	Standard

SQUEEGEE SIZE	LINATEX BLADE KIT	GUM RUBBER BLADE KIT	URETHANE BLADE KIT	COMPLETE SQUEEGEE ASSEMBLIES
31" Squeegee	231-770L	231-770G	231-770U	231-7180
33" Squeegee	233-770L	233-770G	233-770U	233-7180
37" Squeegee	237-770L	237-770G	237-770U	237-7180

SQUEEGEE MATERIAL:	USED FOR:
LINATEX	Provides best wear and tear resistance. Not designed for use with harsh chemicals.
URETHANE	Provides best resistance when dealing with harsh chemicals, oils, fuels, etc.
GUM	Provides best drying performance on rough/grouted floor types by sealing over irregularities. Short life.

NOTICE

Squeegee blade kits include (1) Rear Blade, (1) Front Blade, and (2) Caster Wheels with hardware.

NOTICE

Squeegee Assemblies (complete) listed above all come with Linatex blades.

NOTICE

Size is denoted by label on top squeegee.





S-SERIES PM SHEET

CUSTOMER & MACHINE INFORMATION			
Customer:		Email:	
Address:		Phone:	
City:	State:	Zip:	Contact:
Serial #:	Model #:	Work Order #:	

NOTE: Start with Machine filled at least with ½ Tank of water. Turn ON Machine and Test Functionality of Machine

CHECK OPERATION & CONDITION OF	IN SPEC	REPAIR	PROBLEM
Key Switch			
Battery Gauge			
Deck Up / Down – Brush Switch			
Brush Pressure +/- Toggle (Optional)			
Vacuum Switch - ON / OFF			
Squeegee Lever - Up/Down			
Solution Switch - ON/OFF			
Solution Flow Lever +/-			
Green Drive Buttons - L & R			
Reverse Toggle Switch			
E-Stop (Optional)			

NOTE: Drain Solution & Recovery Tank fully. Rinse out Recovery Tank

CLEAN & INSPECT – SOLUTION TANK	IN SPEC	REPAIR	PROBLEM
Solution Fill Screen - Mesh			
Solution Fill Hose (Optional)			
Solution Inline Filter			
Vacuum Muffler Drain Hose			
Battery Drain Hose			

BRUSH CONDITION – SCRUB DECK			
Deck Curtains/Wipers	Good		Worn Needs Replacement
Brush Sockets: (2-Disk)/(4-Cylindrical)	Good		Worn Needs Replacement
Brush Drivers: (2-Disk)/(4-Cylindrical)	Good		Worn Needs Replacement
Scrub Brush Fiber Length	Brush 1 Length:	Brush 2 Length:	Rotated Brushes: Y / N

CLEAN & INSPECT – SCRUB DECK	IN SPEC	REPAIR	PROBLEM
Scrub Deck Linkage Pivot Points			
Scrub Deck Lift Actuator			
Scrub Deck Level (Orbital Only)			
Scrub Motor Wires			

CLEAN & INSPECT - SQUEEGEE	IN SPEC	REPAIR	PROBLEM
Remove and Wipe off Squeegee			
Check and Rotate Blades as Needed			
Caster Wheels and Height			
Pitch Adjust			
Check Pivot and Knobs			
Squeegee Vac Hose			

CLEAN & INSPECT – RECOVERY TANK	IN SPEC	REPAIR	PROBLEM
Recovery Tank Lid & Gasket			
Vacuum Float Ball Screen			
Vacuum Box White Filter			
2" Round Final Vac Screen			
Solution Site Tube			

CLEAN & INSPECT – DRIVE	IN SPEC	REPAIR	PROBLEM
Drive Wheels & Casters Condition			
Grease Caster Swivel			

Battery Chargers

Console / WET / Domestic Chargers:

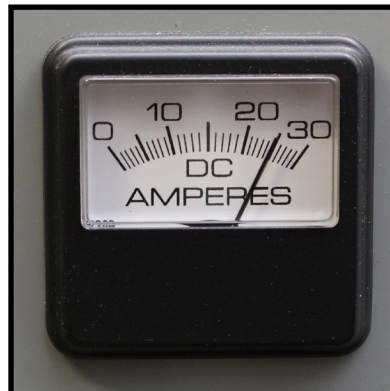

AC Power IN: 120VAC / 60Hz
DC Power OUT: 24VDC / 12A

Please refer to OEM Charger Operating Instructions for more information.



Onboard / AGM / International Chargers:

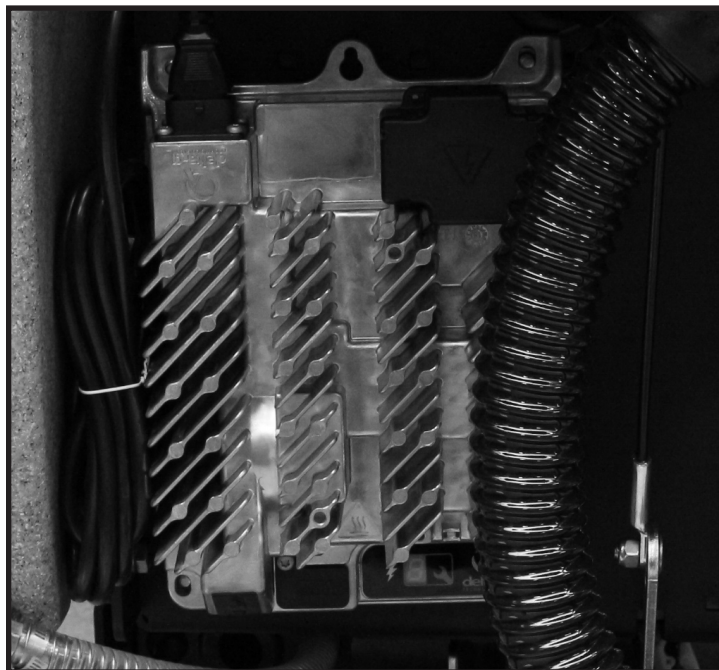

AC Power: 80-270VAC / 50-60Hz
DC Power OUT: 24VDC / 25A





























Please refer to OEM Charger Operating Instructions for more information.



Status Light error codes

Status Light Guide















Below is a list of self-help actions. Try to use this list before you contact your service agent. Go to the number in the list which matches the number of indicator light flashes and follow the instructions.

1 Flash   	The battery needs charging, there is a bad connection to the battery or dependent on programming, may indicate that the battery lockout function is active and the controller is in a restricted mode of operation. Check the connections to the battery. If the connections are good, try charging the battery.
2 Flash   	There is a bad connection to the motor. Check all connections between the motor and the controller.
3 Flash   	The motor has a short circuit to a battery connection. Contact your service agent.
4 Flash   	The battery charge level has fallen below the Battery Lockout Level and the controller is inhibiting certain machine functions. Charge the battery.
5 Flash  	Not Used.
6 Flash   	The controller is being inhibited from driving, this may be because the battery charger is connected.
7 Flash   	A throttle fault is indicated. Make sure that the throttle is in the rest position before switching on the machine.
8 Flash   	A controller fault is indicated. Make sure that all connections are secure.
9 Flash   	The parking brakes have a bad connection. Check the parking brake and motor connections. Make sure the controller connections are secure.
10 Flash  	An excessive voltage has been applied to the controller. This is usually caused by a poor battery connection. Check the battery connections.

Status Light Guide

Below is a list of self-help actions. Try to use this list before you contact your service agent. Go to the number in the list which matches the number of indicator light flashes and follow the instructions.

Flash

x1 	Motor Overcurrent Error (shutdown). The controller stopped the motor to protect the drive due to excessive current peak Restart the controller by cycling the keyswitch
x2 	Max temperature Error. The controller stopped the motor due to excessive temperature of the electronic power stage. Restart the controller by cycling the keyswitch after allowing the controller to cool down.
x3 	Motor I2T Error. The controller stopped the motor because the current was detected above the defined setpoint beyond the set time. Restart the controller by cycling the keyswitch after allowing the controller to cool down.
x4 	Battery voltage Error (value above minimum setpoint. The controller stopped the motor for insufficient battery voltage. Restart the controller by cycling the keyswitch after charging the battery.
x5 	Battery voltage Error (value above maximum setpoint). The controller stopped the motor for too high battery voltage. Restart the controller by cycling the keyswitch after restoring the normal battery level.
x8 	Battery threshold 4 warning. Voltage under the battery threshold 4. to restore, verify the battery voltage and then restart the controller.
x12 	Current threshold Error. The current absorbed by the motor was higher than the limiting current setpoint.Restart the controller by cycling the keyswitch.
x13 	Current throttling Error (time ended). The current absorbed by the motor was higher than the limiting current setpoint for longer than set. Restart the controller by cycling the keyswitch.
x15 	Motor disconnected Error. Current threshold Error. The current absorbed by the motor was higher than the limiting current setpoint.Restart the controller by cycling the keyswitch.
x16 	Maximum peak battery Error. The controller detected the battery ADC value higher than the setpoint. Restart the controller by cycling the keyswitch after checking the battery.
x17 	Minimum peak battery Error. The controller detected the battery ADC value lower than the setpoint. Restart the controller by cycling the keyswitch after checking the battery.
x23 	Potentiometer fault Error. The controller detected a potentiometer value reading not correct. Restart the controller by cycling the keyswitch after checking the potentiometer wire/ functionality.
x26 	Motor HW current limit Error. This error indicates that the controller is detecting shutdown signals due to high current. To restore verify the traction motor and the cables and then restart the machine.
x27 	Charger Inhibit warning. When the charger is giving inhibit signal the controller disables all normal functionalities and goes in an error state. To restore the standard functionality, disconnect the Charger from the AC plug and be sure the inhibit signal from the charger to the controller is removed.



P# 260-1520



P# 260-7201

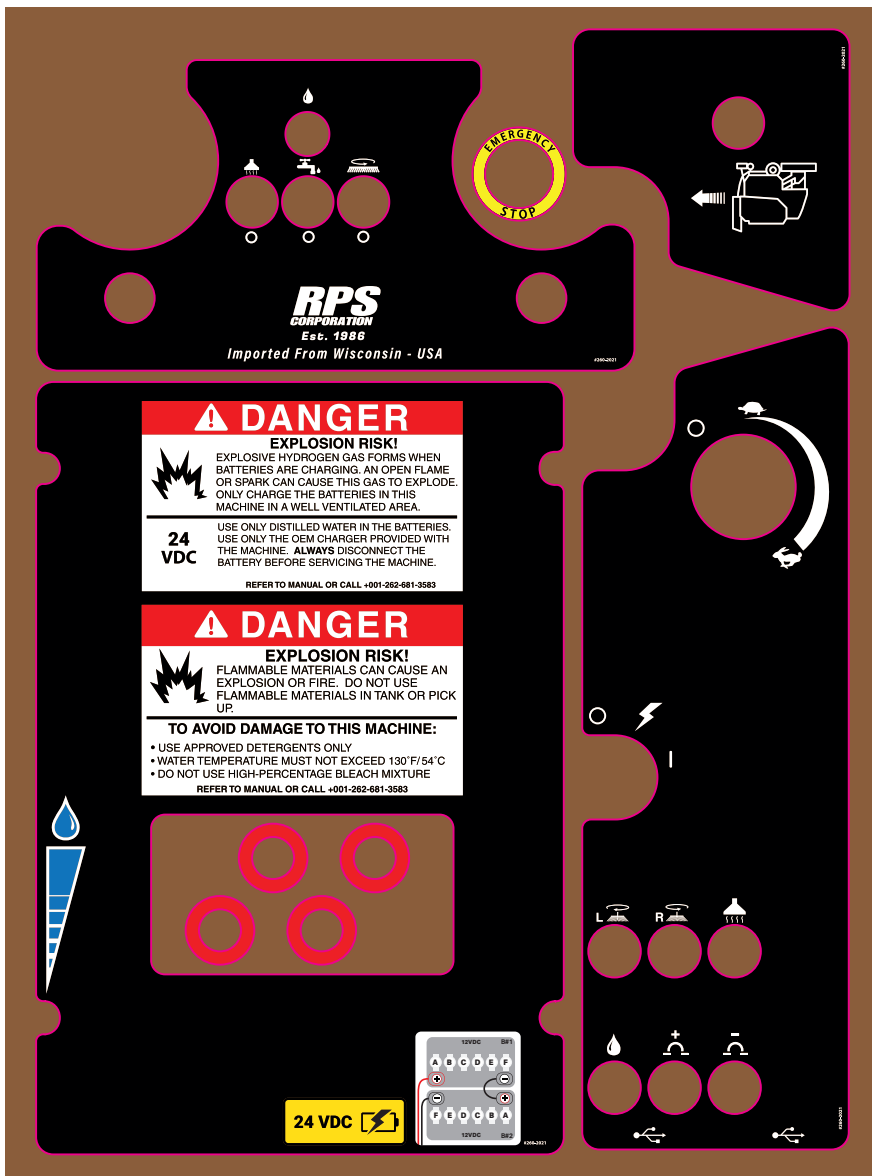

P# 260-2021

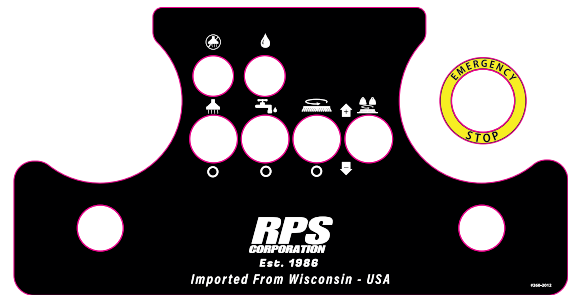

P# 260-2012



P# 260-020D



P# 260-020O



P# 260-024O

BLANK

THIS PAGE WAS INTENTIONALLY LEFT BLANK



www.timberlineclean.com
1711 South Street
Racine, WI 53404 (USA)
262-833-4040 | (877) 401-0730
© 2023 RPS Corporation

V23341
T-S-SERIES-OP-EN